

UNITED STATES
NUCLEAR REGULATORY COMMISSION

WASHINGTON, D.C. 20555-0001

December 12, 2001



Mr. J. Troy Martel, P.E.
Triconex Nuclear Qualification Project Director
Triconex Corporation
15345 Barranca Parkway
Irvine, California 92618

SUBJECT: REVIEW OF TRICONEX CORPORATION TOPICAL REPORTS 7286-545, "QUALIFICATION SUMMARY REPORT" AND 7286-546, "AMENDMENT 1 TO QUALIFICATION SUMMARY REPORT," REVISION 1 (TAC NO. MA8283)

Dear Mr. Martel:

The NRC staff has completed its review of the subject topical report which was submitted by Triconex Corporation by letter dated October 2, 2000. This document was also submitted to the NRC by the Electric Power Research Institute (EPRI) as a technical report entitled, "Generic Qualification of the Triconex Corporation Tricon Triple Modular Redundant Programmable Logic Controller System for Safety-Related Application in Nuclear Power Plants," document number 1000799, dated November 2000. By letter dated March 20, 2001, Triconex Corporation amended its original qualification summary report by submitting Topical Report 7286-546, "Amendment 1 to Qualification Summary Report," Revision 0, dated March 19, 2001. This amendment requested that the NRC review and approve an update of the Triconex Programmable Logic Controller (PLC) from Version 9.3.1 to Version 9.5.3.

By letter dated June 26, 2001, Triconex Corporation again revised its qualification summary report by submitting Topical Report 7286-546, "Amendment 1 to Qualification Summary Report," Revision 1, dated June 25, 2001. This revision updated the Triconex part number for the 3636TN relay output module and the 3601TN 115 Vac digital output module, and revised the EAO software listing used in the 3805EN analog output module. In addition, together with the original qualification summary report, this revision asked the staff to approve the Triconex system and several module types for safety-related use in nuclear power plants.

The staff has found that Topical Reports 7286-545, "Qualification Summary Report" and 7286-546, "Amendment 1 to Qualification Summary Report," Revision 1 are acceptable for referencing in licensing applications for nuclear power plants to the extent specified and under the limitations delineated in the report and in the associated safety evaluation. The safety evaluation defines the basis for acceptance of the reports.

Pursuant to 10 CFR 2.790, we have determined that the enclosed safety evaluation does not contain proprietary information. However, we will delay placing the safety evaluation in the public document room for a period of ten (10) working days from the date of this letter to provide you with the opportunity to comment on the proprietary aspects only. If you believe that any information in the safety evaluation is proprietary, please identify such information line by line and define the basis pursuant to the criteria of 10 CFR 2.790.

We do not intend to repeat our review of the matters described in the subject reports, and found acceptable, when the reports appear as a reference in license applications, except to ensure that the material presented applies to the specific plant involved. Our acceptance applies only to matters approved in the reports.

In accordance with procedures established in NUREG-0390, the NRC requests that Triconex Corporation publish accepted versions of the submittals, proprietary (-P) and non-proprietary (-NP), within 3 months of receipt of this letter. The accepted versions shall incorporate (1) this letter and the enclosed safety evaluation between the title page and the abstract, and (2) all requests for additional information from the staff and all associated responses, and (3) an "-A" (designating "accepted") following the report identification symbol.

Should our criteria or regulations change so that our conclusions as to the acceptability of the reports are invalidated, Triconex Corporation and/or the applicants referencing the topical reports will be expected to revise and resubmit their respective documentation, or submit justification for the continued applicability of the topical reports without revision of their respective documentation.

Sincerely,

A handwritten signature in black ink, appearing to read 'S. Richards', with a large, stylized flourish at the end.

Stuart A. Richards, Director
Project Directorate IV
Division of Licensing Project Management
Office of Nuclear Reactor Regulation

Project No. 709

Enclosure: Safety Evaluation

Mr. J. Troy Martel

- 2 -

We do not intend to repeat our review of the matters described in the subject reports, and found acceptable, when the reports appear as a reference in license applications, except to ensure that the material presented applies to the specific plant involved. Our acceptance applies only to matters approved in the reports.

In accordance with procedures established in NUREG-0390, the NRC requests that Triconex Corporation publish accepted versions of the submittals, proprietary (-P) and non-proprietary (-NP), within 3 months of receipt of this letter. The accepted versions shall incorporate (1) this letter and the enclosed safety evaluation between the title page and the abstract, and (2) all requests for additional information from the staff and all associated responses, and (3) an "-A" (designating "accepted") following the report identification symbol.

Should our criteria or regulations change so that our conclusions as to the acceptability of the reports are invalidated, Triconex Corporation and/or the applicants referencing the topical reports will be expected to revise and resubmit their respective documentation, or submit justification for the continued applicability of the topical reports without revision of their respective documentation.

Sincerely,

/RA/

Stuart A. Richards, Director
Project Directorate IV
Division of Licensing Project Management
Office of Nuclear Reactor Regulation

Project No. 709

Enclosure: Safety Evaluation

DISTRIBUTION:

PUBLIC (No DPC folder for 10 working days)

PDIV-2 Reading

SRichards (RidsNrrDlpmLpdiv)

RWharton (RidsNrrPMRWharton)

EPeyton (RidsNrrLAEPeyton)

JCalvo

EMarinos

PLoeser

RidsOgcMailCenter

RidsAcrcAcnwMailCenter

*For previous concurrence see attached ORC

ACCESSION NO.: ML013470433

OFFICE	PDIV-2/PM	PDIV-2/LA	EEIB/SC*	PDIV-2/SC	PDIV/D
NAME	RWharton:esp	EPeyton	EMarinos	SDembek	SRichards
DATE	12/6/01	12/6/01	11/29/01	12/11/01	12-10-01

OFFICIAL RECORD COPY

Contents	Page
1.0 INTRODUCTION	1
2.0 SYSTEM DESCRIPTION	4
2.1 Hardware Description	5
2.1.1 Chassis	5
2.1.1.1 Main Chassis	5
2.1.1.2 Expansion Chassis	6
2.1.1.3 Remote Extender Chassis	6
2.1.1.4 External Termination Assemblies	7
2.1.1.5 Power Supply Modules	7
2.1.2 Main Processor Subsystem	8
2.1.3 Input and Output Modules	10
2.1.3.1 Digital Input Modules	12
2.1.3.2 Analog Input Modules	13
2.1.3.3 Digital Output Modules	13
2.1.3.4 Analog Output Module	14
2.1.3.5 Pulse Input Module	14
2.1.3.6 Thermocouple Input Modules	14
2.1.3.7 Relay Output	15
2.1.4 Communications Modules	15
2.2 Software Description	16
2.2.1 Safety-Related Operating System Software Description	17
2.2.1.1 Main Processor Module Software	17
2.2.1.1.1 TSX Operating Environment Software	17
2.2.1.1.2 IOC Software	19
2.2.1.1.3 COM Software	19
2.2.1.2 I/O Module Software	19
2.2.1.3 Communications Module Software	21
2.2.2 Safety-Related Plant-Specific Application Software	22
2.2.3 TriStation 1131 Software	22
2.3 Tricon PLC Product Qualifications	24
2.3.1 Environmental Requirements	24
2.3.2 EMI/RFI Requirements	25
2.3.3 Electrostatic Discharge (ESD) Withstand Requirements	25
2.3.4 Seismic Withstand Requirements	25
2.3.5 Surge Withstand Requirements	25
2.3.6 Class 1E to Non-1E Isolation Requirements	25
3.0 REVIEW CRITERIA	26
3.1 General Standards	26
3.2 Method of Review	28
4.0 EVALUATION	29
4.1 Tricon PLC Hardware Design Review	29
4.1.1 Hardware Architecture and Signal Flow	29
4.1.2 Hardware Quality	30

4.1.3	Environmental Testing and Qualification	32
4.1.3.1	Pre-qualification Testing	32
4.1.3.2	Temperature and Humidity Testing	33
4.1.3.3	Radiation Withstand Testing	35
4.1.3.4	Seismic Withstand Testing	35
4.1.3.5	Electromagnetic Compatibility Testing	36
4.1.3.6	Surge Withstand Testing	38
4.1.3.7	ESD Withstand Testing	39
4.1.3.8	Class 1E to Non-1E Isolation Testing	40
4.2	Tricon PLC Software Design Review	41
4.2.1	Software Documentation	41
4.2.2	Software Development and Life Cycle Planning	42
4.2.2.1	Software Management Plan	44
4.2.2.2	Software Development Plan	44
4.2.2.3	Software Quality Assurance Plan	44
4.2.2.4	Software Integration Plan	45
4.2.2.5	Software Installation Plan	45
4.2.2.6	Software Maintenance Plan	45
4.2.2.7	Software Training Plan	45
4.2.2.8	Software Operations Plan	46
4.2.2.9	Software Safety Plan	46
4.2.2.10	Software Verification and Validation Plan	46
4.2.2.11	Configuration Management and Error Notification	49
4.2.3	Evaluation of TriStation 1131 Programming Software	50
4.2.4	Application Programs	51
4.3	Tricon PLC System Design Review	51
4.3.1	Failure Modes and Effects Analysis	52
4.3.2	Reliability and Availability Analysis	52
4.3.3	Component Aging Analysis	52
4.3.4	Thread Audit	53
4.3.5	Response Time Characteristics	54
4.3.6	Tricon PLC System Self-Diagnostic Capacity	55
4.3.7	Training	56
4.3.8	Repair of Tricon PLC System Modules	58
4.3.9	Historic Data on Tricon PLC System Use	58
4.3.10	Defense-in-Depth and Diversity	58
5.0	CONCLUSION	60
5.1	Regulatory Compliance	60
5.2	Plant-Specific Requirements	63
5.3	Approval	66

LIST OF FIGURES

Figure 1-	Tricon PLC Architecture	4
Figure 2-	Main Chassis Backplane	6
Figure 3-	Main Processor Architecture	9

SAFETY EVALUATION BY THE OFFICE OF NUCLEAR REACTOR REGULATION

TOPICAL REPORTS 7286-545 AND 7286-546

"QUALIFICATION SUMMARY REPORT" AND "AMENDMENT 1 TO QUALIFICATION

SUMMARY REPORT," REVISION 1

TRICONEX CORPORATION

PROJECT NO. 709

1.0 INTRODUCTION

By letter dated October 2, 2000, Triconex Corporation (Triconex) submitted Topical Report 7286-545, "Qualification Summary Report," dated September 18, 2000 (ADAMS Accession Number ML003757032), for review by the staff of the U. S. Nuclear Regulatory Commission.

This document was also submitted to the NRC by the Electric Power Research Institute (EPRI) as a technical report entitled, "Generic Qualification of the Triconex Corporation Tricon Triple Modular Redundant Programmable Logic Controller System for Safety-Related Application in Nuclear Power Plants," document number 1000799, dated November 2000.

By letter dated March 20, 2001, Triconex amended its original qualification summary report by submitting Topical Report 7286-546, "Amendment 1 to Qualification Summary Report," Revision 0, dated March 19, 2001 (ADAMS Accession Number ML010810143). This amendment requested that NRC review and approve an update of the Triconex Programmable Logic Controller (PLC) from Version 9.3.1 to Version 9.5.3.

By letter dated June 26, 2001, Triconex again revised its qualification summary report by submitting Topical Report 7286-546, "Amendment 1 to Qualification Summary Report," Revision 1, dated June 25, 2001 (ADAMS Accession Number ML011790327). This revision updated the Triconex part number for the 3636TN relay output module and the 3601TN 115 Vac digital output module, and revised the EAO software listing used in the 3805EN analog output module. In addition, together with the original qualification summary report, this revision asked the staff to approve the Triconex system and the following module types for safety-related use in nuclear power plants:

<u>MODULE TYPE</u>	<u>MODEL</u>	<u>DESCRIPTION</u>
Chassis	8110N	Main Chassis
	8111N	Expansion Chassis
	8112N	Remote Expansion Chassis

Main Processor	3006N	Enhanced Main Processor 11, V9, 2 Mb
Remote Extender	4210N 4211N	Remote Extender Module (Primary) Remote Extender Module (Remote)
Communication	4119AN 4329N 4609N	Enhanced Intelligent Communications Module (EICM) V9, Isolated Network Communications Module (NCM), V9 Advanced Communications Module (ACM)
Analog Input	3700AN 3701N 3703EN 3704EN	Analog Input (AI) Module, 0/5 Vdc, 6% Overrange AI Module, 0/10 Vdc Enhanced Isolated Analog Input (EAI) Module High-Density Analog Input (HDAI) Module, 0-5/0-10 Vdc
Analog Output	3805EN	Analog Output Module, 4/20 mA
Digital Input	3501TN 3502EN 3503EN 3504EN 3505EN	Enhanced Digital Input (EDI) Module, 115V ac/dc EDI Module, 48V ac/dc EDI Module, 24V ac/dc High-Density Digital Input (HDDI) Module, 24/48 Vdc EDI Module, 24 Vdc, Low-Threshold
Digital Output	3601TN 3603TN 3604EN 3607EN 3623TN 3624N	Enhanced Digital Output (EDO) Module, 115 Vac EDO Module, 120 Vdc EDO Module, 24 Vdc EDO Module, 48 Vdc Supervised Digital Output (SDO) Module, 120 Vdc SDO Module, 24 Vdc
Pulse Input	3510N	Pulse Input Module
Thermocouple Input	3706AN 3708EN	Non-Isolated Thermocouple (NITC) Input Module Isolated Thermocouple (ITC) Input Module
Relay Output	3636TN	Enhanced Relay Output (ERO) Module, Simplex
Power Supply	8310N 8311N	120 Vac/DC Power Supply 24 Vdc Power Supply

Since March 21, 2000, Triconex has also provided a variety of related documents under cover of the following eleven letters:

<u>Date</u>	<u>Adams Accession Number</u>
March 21, 2000	ML003702538
March 21, 2000	ML003721491
April 3, 2000	ML003700550
July 17, 2000	ML003733651

<u>Date</u>	<u>Adams Accession Number</u>
August 29, 2000	ML003746068
September 29, 2000	ML003756705
November 14, 2000	ML003769998
November 15, 2000	ML003769918
February 27, 2001	ML010610188
August 30, 2001	ML012490183
September 25, 2001	ML012700039

These submittals provided the following documents:

<u>Document Title</u>	<u>Triconex Document Number</u>
Quality Plan (Nuclear Qualification Project)	QPL-0 I
Quality Assurance Manual	QAM
Master Test Plan	7286-500
Setup and Check-out Test Procedure	7286-502
Operability Test Procedure	7286-503
Prudency Test Procedure	7286-504
Environmental Test Procedure	7286-506
Seismic Test Procedure	7286-507
Surge Withstand Test Procedure	7286-508
1E/Non-1E Isolation Test Procedure	7286-509
EMI/RFI Test Procedure	7286-510
TSAP Validation Test Procedure	7286-513
TSAP Functional Specification	7286-517
TSAP Design Specification	7286-518
TSAP Program Listing	7286-519
Pre-Qualification Test Report	7286-524
Environmental Test Report	7286-525
Seismic Test Report	7286-526
EMI/RFI Test Report	7286-527
Surge Test Report	7286-528
1E/Non-1E Isolation Test Report	7286-529
Performance Proof Test Report	7286-530
Reliability/Availability Study	7286-531
Failure Modes & Effects Analysis	7286-532
Radiation Hardness Evaluation	7286-533
Tricon PLC System Accuracy Specification	7286-534
Software Qualification Report	7286-535
TSAP V&V Report	7286-536
Software Quality Assurance Plan	7286-537
Master Configuration List	7286-540
Tricon PLC Test Specimen Description	7286-541
Certificate of Conformance	7286-542
Maximum Response Time Calculation	426-001/SCS-01
Triconex Training Manual	5600-0020/99
Technical Product Guide, V 8	9791007-002
Technical Product Guide, V 9	9791007-005

Document Title

Tricon Planning and Installation Guide
Test System Loop Diagrams
Type Approval of Tricon Version 9.5.3
Advanced Communications Module
Intelligent Communications Module
TriStation Multi System Workstation
TriStation Developers Workbench

Triconex Document Number

9720051-006
Various
TÜV-Rheinland 968/EZ 105.02/01
None (commercial manual)
None (commercial manual)
None (commercial manual)
None (commercial manual)

For documents that contained proprietary information, Triconex also submitted nonproprietary versions.

2.0 SYSTEM DESCRIPTION

The Tricon PLC system is a fault-tolerant PLC that uses a triple modular redundant (TMR) architecture in which three parallel control paths are integrated into a single overall system. The system is designed to use two-out-of-three voting with the intent of providing uninterrupted process operation with no single point of random hardware failure. However, since all three of the parallel paths use identical hardware and software, common- cause failure is possible in both hardware and software.

A Tricon PLC system consists of 1 main chassis and up to 14 expansion chassis. The main chassis contains: (1) two redundant power supply modules, (2) three main processor modules, (3) communications modules, and (4) input and output (I/O) modules.

Figure 1 shows the data flow in the TMR architecture of the Tricon PLC system. When entering the input module, the signals from each attached sensor are separated into three isolated paths and sent to one of the three main processor modules. The TriBus inter-processor bus performs a two-out-of-three vote on data and corrects any discrepancies. This process ensures that each main processor uses the same voted data to execute its application program.

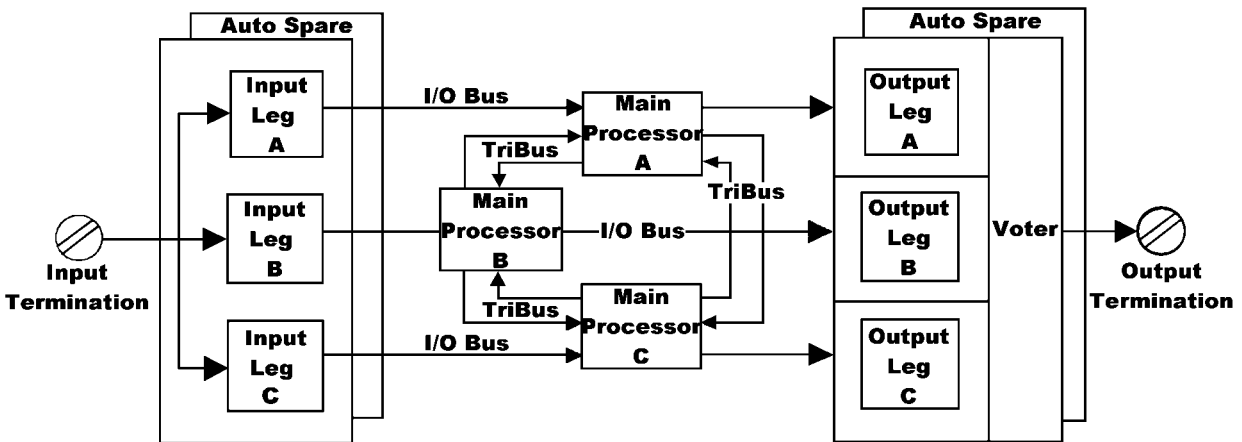

Figure 1. TMR Architecture of the Tricon PLC System

Similarly, process outputs are sent via triplicated paths to the output modules, which in turn send the data to a voter using two-out-of-three logic. The voted output is then sent to the actuation devices by an output termination board.

2.1 Hardware Description

The hardware which makes up the Tricon PLC system consists of the three types of chassis, the external termination assemblies, the power supply modules, the main processor subsystem, and various I/O and communication modules, depending on the configuration and use of the system. These components are described in Sections 2.1.1- 2.1.4.

2.1.1 Chassis

The Tricon PLC system can accommodate various combinations of the main chassis and up to 14 expansion chassis and/or remote extender chassis. The main chassis contains the main processor modules and a combination of I/O and communications modules. The expander chassis is used locally to increase the number of I/O modules in the system, and is connected via RS-485 communication links. The remote extender chassis is used for remote locations up to several miles away, and is connected via fiber optic links.

2.1.1.1 Main Chassis

The main chassis of the Tricon PLC system contains two power supplies, three main processor modules, and communications and I/O modules as needed. It also has a key switch with the following positions to set the system's operating mode:

- RUN is the normal operating mode, which gives read-only capability by externally connected systems including the TriStation. The switch is normally set to this position, and the key is removed and stored in a secured location.
- PROGRAM mode allows the Tricon PLC system to be controlled from an externally connected personal computer (PC) running the TriStation software. This mode is needed to download application programs to the Tricon PLC system.
- STOP terminates the execution of the current application program.
- REMOTE allows a TriStation PC or a Modbus master or external host to write values to application program variables.

The main chassis backplane of the Tricon PLC system has dual power rails, each of which has an independent power supply with sufficient capacity to power the entire chassis. Under normal circumstances, each main processor module and each of the three legs on I/O modules draw power from both power supplies through the dual power rails and the dual voltage regulators. If either of the power supplies or its supporting power line fails, the other power supply will increase its output to support the power needs of all modules in the chassis. Figure 2 shows the power supply architecture of the main chassis backplane.

The Tricon PLC system also has two redundant batteries located on the main chassis backplane. If a total power failure occurs, these batteries maintain data and programs on the main processor modules for a period of 6 months. The system will generate an alarm when the battery power is too low to support the system.

2.1.1.2 Expansion Chassis

The expansion chassis are used locally to increase the number of I/O modules in the Tricon PLC system. Each expansion chassis is connected to the main chassis via three RS-485 communication links (one for each of the three I/O legs). If communications modules are installed, three separate RS-485 links are required for the three communications buses. The maximum length of the RS-485 cables is 100 feet. The Tricon PLC expansion chassis has the same type of power supplies as the main chassis, and the same dual and redundant power bus arrangement. Each expansion chassis can support I/O modules, but only the first expansion chassis can support communications modules.

2.1.1.3 Remote Extender Chassis

The remote extender chassis are similar to the expansion chassis, but are used for remote locations (up to several miles away), rather than locally. As such, each remote extender chassis has remote extender modules (RXMs) that serve as repeaters or extenders of the Tricon PLC I/O bus to allow communications with the main chassis and expansion chassis. The RXMs are single-mode fiber optic modules that allow the expansion chassis to be located up to 7.5 miles away from the main chassis. Each RXM module has separate transmit and receive cabling ports, requiring two unidirectional fiber optic cables (one to transmit and one to receive), for each module. Since the RXM modules are connected by fiber optic cables and not electrical

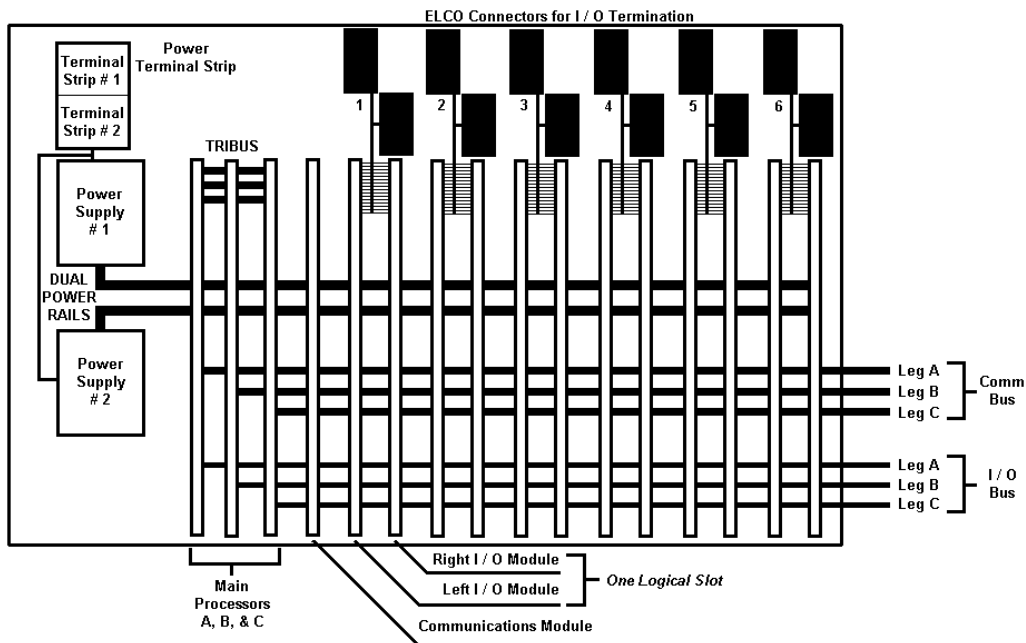

Figure 2. Main Chassis Backplane

cables, they provide ground loop isolation and immunity against electrostatic and electromagnetic interference, and they can be used as 1E-to-non-1E isolators between a safety-related main chassis and a non safety-related expansion chassis. The Tricon PLC remote extender chassis uses the same type of power supplies as the main chassis, and has the same dual and redundant power bus arrangement.

2.1.1.4 External Termination Assemblies

Each I/O module in the Tricon PLC system has an external termination assembly (ETA) mounted on the chassis in which it is contained. These are printed circuit board panels that are used to terminate field wiring. The panels contain terminal blocks, resistors, fuses, and blown fuse indicators. The panels are configured for specific applications, depending on which I/O modules are used. Thermocouple input termination panels provide cold-junction temperature sensors and are available with upscale, downscale, or programmable burnout detection. Resistance temperature detector (RTD) termination panels include signal conditioning modules. Each ETA panel includes an interface cable that connects the panel to the chassis backplane.

2.1.1.5 Power Supply Modules

All power supply modules are rated for 175 watts, which is sufficient to supply the power requirements of a fully populated chassis. A single chassis can accommodate the two different types of power supply modules available for nuclear power plants. Specifically, the available types of power supplies are the 120 V ac/dc Model # 8310N and the 24 V dc Model #8311N. Each of these power supply modules possesses built-in diagnostic circuitry to check for out-of-range voltages and over-temperature conditions. Light-emitting diodes (LEDs) on the front face of each power supply module indicate the module status.

The power supply modules also contain the system alarm contacts. The chassis backplane provides terminal strip interfaces for power and alarm connections. The alarm feature operates independently for each power module. On the main chassis, the power supply modules will alarm on the following states:

- System configuration does not match the control program configuration.
- A digital output module experiences a load/fuse error.
- A configured module is missing somewhere in the system.
- A module is inserted in an unconfigured slot.
- A fault is detected on a main processor or I/O module in the main chassis.
- A fault is detected on an I/O module in an expansion chassis.
- A main processor detects a system fault.
- The inter-chassis I/O bus cables are incorrectly installed (i.e., cross-connected).

The system alarm contacts on at least one of the power supply modules will also actuate when any of the following power conditions exist(s):

- A power module fails.
- Primary power to a power supply module is lost.
- A power module has a low battery or over-temperature condition.

The system alarm contacts on *both* power modules of an expansion chassis will actuate when a fault is detected on an I/O module.

2.1.2 Main Processor Subsystem

The main processor (MP) subsystem contains three MP modules, each of which is independent, resides on a separate printed circuit board, controls a separate leg of the system, and operates in parallel with the other two main processors. Each MP module contains three microprocessors, which are the 8-bit I/O communications (IOC) processor, the 8-bit communications (COM) processor for external communications, and the 32-bit primary processor. The primary processor manages execution of the control program and all system diagnostics at the main processor module level and has a 32-bit math co-processor. Each 8-bit processor and the 32-bit primary processor are connected via a dedicated dual port random access memory (RAM) allowing for direct memory access data exchanges. The operating system, run-time library, and fault analysis for the main processor are fully contained in read-only memory (ROM) on each MP module.

As shown in Figure 3, the Tricon PLC system has four separate bus structures, the Tribus, the communications bus, the I/O bus, and the bus internal to each of the main processor modules. Each of these bus structures is triplicated. The Tribus interconnects the three MP modules with each other, and is used for data transfer, voting, and program loading. The communications bus connects the MP modules with the communications modules and is used to send non-safety data to other Tricon PLC and non-Tricon PLC systems. The I/O bus connects the MP modules to the I/O modules, both within the main chassis and from chassis to chassis by means of I/O bus cables. The internal bus in each MP module interconnects the processors with the dual-port RAM, erasable programmable read only memory (EPROM), static random access memory (SRAM), direct memory access (DMA) devices, the timing generator and the interrupt controller.

The MP subsystem makes limited use of interrupts. The interrupt controller sends periodic interrupts to the background diagnostics and fault analysis tasks to trigger execution of the foreground task containing the control program. The "watchdog" can trigger an interrupt to inform the MP of a problem. In addition, the I/O processor uses interrupts generated by the I/O bus to request data from the I/O modules.

The MP modules communicate with each other through the Tribus. Each MP module has an I/O bus channel to allow communication with one of the three legs of each I/O module. Each MP module also has an independent clock circuit and clock selection mechanism that enables all three MP modules to synchronize their operations during each scan to allow voting of data and exchange of diagnostic information.

The I/O processor polls each I/O input module using the attached leg of the I/O bus, and stores the received value in the memory that is dual-ported to the I/O processor and the main processor. This makes the received value available for retrieval by the main processor.

In a similar manner, the communications processor manages the data exchanged between the main processors and the communications modules. The communications bus supports a broadcast mechanism, and stores the received value in the dual-ported memory, where it is available for retrieval by the main processor. The values in each MP module are transferred to the next MP module over the Tribus. Hardware voting also takes place during this transfer. The Tribus uses direct memory access to synchronize, transmit, vote, and compare data among the three main processors. If a disagreement occurs, the value found in two out of three tables prevails, and the third table is corrected accordingly. One-time differences that result from sample timing variations are distinguished from a pattern of differing data. Each main processor maintains data about the necessary corrections in local memory. Any disparity is flagged and used at the end of the scan by the built-in fault analyzer routines of the Tricon PLC system to determine whether a fault exists in a particular module.

The main processors enter the corrected data into the control program. The 32-bit main microprocessor and math coprocessor execute the control program in parallel with the other two main processor modules. The control program generates output values on the basis of input values according to customer-defined rules that are built into the application. The I/O communication processor on each main processor manages the transmission of output data to the output modules by means of the I/O bus.

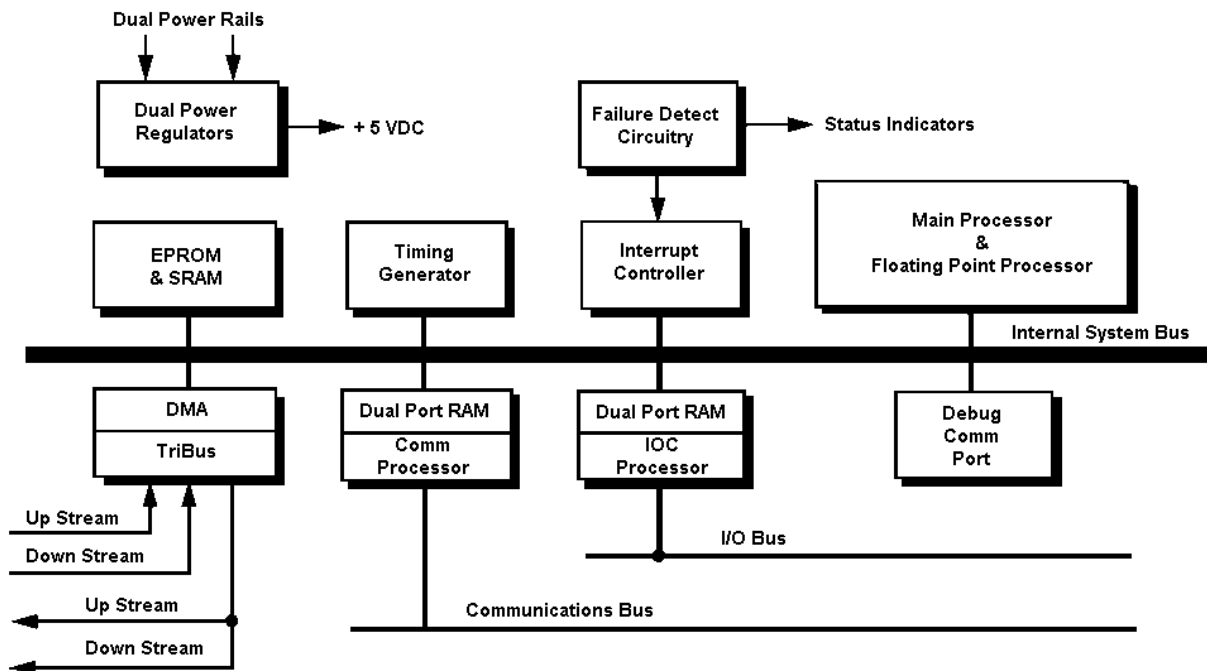

Figure 3. Main Processor Architecture

Each MP module has the following indicator lights on the front panel of each card:

- Pass: If on, the module has passed its self-diagnostic tests.
- Fault: If on, the module has a fault.
- Active: If on, the module is running the user-written control program.
- Maint1: The module is re-educating when this indicator light is blinking.
- Maint2: If on, the module has a high soft-error count.

The front panel also has four lights that show communication status, when the card is transmitting or receiving on either the communications bus or the I/O bus. In addition, the front panel has a History/Status port that can be used to read the diagnostic information on the given board. The History/Status port is generally not available for users, but is provided for depot-level repair by personnel from Triconex.

The only model of MP module available for safety-related use in nuclear power plants is the model 3006N, which provides 2 MB of SRAM. This SRAM is used for the plant-specific control program, I/O data, diagnostics, and communication buffers. In the event of an external power failure, the SRAM is protected by batteries that reside on the main chassis backplane. In the absence of power to the Tricon PLC system, the batteries maintain the integrity of the program and the retentive variables for six months.

Triconex also offers the Model 3007 main processor, which is intended for use as a single chassis Tricon PLC system. However, Triconex did not submit the Model 3007 for staff review and therefore it is not qualified for safety-related use in nuclear power plants.

2.1.3 Input and Output Modules

Each input module consists of three identical and independent circuits, called legs, contained on a single input card. The isolated input on each leg of each input module receives sensor outputs that are received on a field termination point. The microprocessor in each leg continually polls the input points, and constantly updates an input data table in the local memory of each leg. Any required signal conditioning, isolation, and processing are also performed independently for each leg. Each input module has leg-to-leg isolation and independence within the I/O board to ensure that a component failure in one leg will not affect the signal processing in the other two legs. Each of the triplicated I/O buses communicates with a single, hardware-defined MP and with one of the triplicated microprocessors on each I/O module. In each MP, the I/O bus microprocessor reads the data and provides it to the MP through a dual port RAM interface. Each MP then transfers and votes on all data over the Tribus.

All input modules include self-diagnostic features designed to detect single failures within the given module. Fault detection capabilities built into various types of input modules include the following:

- The input data from the three legs is compared at the main processor, and persistent differences generate a diagnostic alarm.

- Digital input modules test for a stuck-on condition by momentarily driving the input for one leg low in order to verify proper operation of the signal conditioning circuitry. A diagnostic alarm is generated if the input module does not respond appropriately.
- Analog input modules include reference voltage sources that are used to continually self-calibrate the analog-to-digital converters. A diagnostic alarm is generated if a converter is found to be out of tolerance.
- Some input modules also include diagnostics to detect field device failures.

Output modules are similar to the input modules, in that each has three identical and independent circuits contained on a single card. All output modules include self-diagnostic features designed to detect single failures within the given module. The major fault detection capabilities built into output modules include the following:

- Digital output modules include output voter diagnostics that toggle the state of one leg at a time to verify that the output switches are not stuck on or off.
- Each supervised digital output module includes a voltage and current loopback circuit that checks for open circuits (e.g., blown fuse) and short circuits in the field wiring.
- Each analog output module includes a voltage and current loopback circuit. On these modules, one of the three legs drives the field load, and the other two legs monitor the loopback current to verify the module's output current is correct.

If one of the three legs within an I/O module fails to function, an alarm is raised to the main processors and is displayed on the power supply module. If a standby module is installed in the paired slot with the faulty module, and that module is itself deemed healthy by the main processors, the system automatically switches over to the standby unit and takes the faulty module off line. If no standby unit is in place, the faulty module continues to operate on two of the three legs, and protection and control are unaffected. To remove the fault in this event, a replacement unit is inserted into the system in the logically paired slot associated with the failed module. When the main processors detect the presence of a replacement module, they initiate diagnostics and, if the module is functioning correctly, automatically switch over to the new module. The faulty module may then be removed and returned to the factory for repair.

If a standby module is installed and both it and its pair are deemed healthy by the main processors, each of the modules is used on a periodic basis. The main processors will automatically swap control between the two modules. By periodically using both modules, any faults are detected and alarmed, and the failed module is replaced when a standby module is in place. This use of standby modules does not cause any interruption of protection or control functions.

The front panel of each I/O module has the following indicator lights that show the status of the card:

- Pass: If on, the module has passed its self-diagnostic tests.
- Fault: If on, one leg within the module has a fault.

- Active: If on, the module is running. (If modules are installed in pairs, one of each pair will be active, and the other in standby.)

The system firmware resident on the I/O modules is designed in a modular fashion, based around a common core. Specific customization, including integral diagnostic capabilities, are applied to fit the needs of a given module and the data to be acquired. All three microprocessors on a module run exactly the same firmware. Each microprocessor interfaces to only one leg of the I/O bus and, thus, to only one MP.

All I/O modules require a cable interface to an external termination panel. Each module is mechanically keyed to prevent improper installation in a configured chassis.

2.1.3.1 Digital Input Modules

The following types of digital input modules are available for safety-related use in nuclear power plants:

- Model 3501TN is a 115 Vac/dc digital input module with 32 isolated input points. This model has standard diagnostics, but does not have the ability to verify the transition of a normally energized circuit to the off state. In addition to the Pass/Fault/Active indicator lights, this module has indicator lights showing if each of the 32 input points is on or off.
- Model 3502EN is a 48 Vac/dc digital input module with 32 inputs. Four groups of 8 inputs use a common reference point. Unlike the Model 3501TN, this model can continuously verify the transition of a normally energized circuit to the off state. In addition to the Pass/Fault/Active indicator lights, this module has indicator lights showing if each of the 32 input points is on or off.
- Model 3503EN is a 24 Vac/dc digital input module with 32 inputs. Four groups of 8 inputs use a common reference point. Like the Model 3502EN, this model can continuously verify the transition of a normally energized circuit to the off state. In addition to the Pass/Fault/Active indicator lights, this module has indicator lights showing if each of the 32 input points is on or off.
- Model 3504EN is a 24/48 Vdc high-density digital input module with 64 inputs that all use a common reference point. Like the Model 3502EN and 3503EN, this model can continuously verify the transition of a normally energized circuit to the off state. In addition to the Pass/Fault/Active indicator lights, this module has indicator lights showing if each of the 64 input points is on or off.
- Model 3505EN is a 24 Vdc low-threshold digital input module with 32 inputs. Four groups of 8 inputs use a common reference point. In addition to the Pass/Fault/Active indicator lights, this module has indicator lights showing if each of the 32 input points is on or off.

2.1.3.2 Analog Input Modules

The following types of analog input modules are available for safety-related use in nuclear power plants:

- Model 3700AN is a 0-5 Vdc analog input module with 32 differential dc-coupled inputs. This model has a +6 percent over-range measurement capability.
- Model 3701N is a 0-10 Vdc analog input module with 32 differential dc-coupled inputs.
- Model 3703EN is a 0-5 or 0-10 Vdc isolated analog input module with 16 differential isolated inputs. This module has a selectable voltage range and upscale or downscale open-input detection and a +6 percent over-range measurement capability.
- Model 3704EN is a 0-5 or 0-10 Vdc high-density analog input module with 64 dc-coupled inputs using a common reference. This module has selectable voltage range and a +6 percent over-range measurement capability.

2.1.3.3 Digital Output Modules

The following types of digital output modules are available for safety-related use in nuclear power plants:

- Model 3601TN is a 115 Vac digital output module with 16 outputs that do not use a common reference point. In addition to the Pass/Fault/Active indicator lights, this module has indicator lights showing if each of the 16 output points is on or off.
- Model 3603TN is a 120 Vdc digital output module with 16 outputs that use a common reference point. In addition to the Pass/Fault/Active indicator lights, this module has indicator lights showing if each of the 16 output points is on or off.
- Model 3604EN is a 24 Vdc digital output module with 16 outputs that do not use a common reference point. In addition to the Pass/Fault/Active indicator lights, this module has indicator lights showing if each of the 16 output points is on or off.
- Model 3607EN is a 48 Vdc digital output module with 16 outputs that do not use a common reference point. In addition to the Pass/Fault/Active indicator lights, this module has indicator lights showing if each of the 16 output points is on or off.
- Model 3623TN is a 120 Vdc supervised digital output module with 16 outputs that use a common reference point. In addition to the Pass/Fault/Active indicator lights, this module has indicator lights showing if each of the 16 output points is on or off.
- Model 3624N is a 24 Vdc supervised digital output module with 16 outputs that use a common reference point. In addition to the Pass/Fault/Active indicator lights, this module has indicator lights showing if each of the 16 output points is on or off.

Each digital output module executes an "output voter diagnostic," in which the state of each point is momentarily reversed to verify that the output is not stuck on or off. Loop-back on the module allows each microprocessor to read the output value for the point to determine whether a latent fault exists within the output circuit. On dc voltage digital output modules, the output signal transition is 2 milliseconds or less and transparent to most field devices. On ac voltage digital output modules, the diagnostic process will cause the output signal to transition to the opposite state for a maximum of half an ac cycle. This transition may not be transparent to all field devices. This feature can be disabled for applications in which the attached devices cannot tolerate a signal transition of this type. Determining the suitability of this feature is a plant-specific requirement.

Supervised digital output modules provide both voltage and current loopback for fault coverage of both energized-to-trip and de-energized-to-trip conditions and verify the presence of the field load through continuous circuit-continuity checks.

2.1.3.4 Analog Output Module

The only analog output module available for safety-related use in nuclear power plants is the Model 3805EN 4-20 mA analog output module. This model has eight dc-coupled outputs, all with a common return. This module provides for redundant loop power sources with individual indicators. If this option is used, the licensee must provide external loop power supplies for analog outputs.

2.1.3.5 Pulse Input Module

The only pulse input module available for safety-related use in nuclear power plants is the Model 3510N pulse input module with 8 inputs that do not use a common reference point. This module senses voltage transitions from magnetic transducer input devices, and counts the number of transitions (or pulses) during a selected period of time. The pulse count is measured to a resolution of 1 microsecond. In addition to the Pass/Fault/Active indicator lights, this module has indicator lights showing if each of the eight input points is on or off.

2.1.3.6 Thermocouple Input Modules

The following types of thermocouple input modules are available for safety-related use in nuclear power plants:

- Model 3706AN is a non-isolated thermocouple input module with 32 differential dc-coupled inputs. This module can support thermocouple types J, K, and T, and can provide upscale or downscale burnout detection depending on the selected field termination.
- Model 3708EN is an isolated thermocouple input module with 16 differential isolated inputs. This module can support thermocouple types J, K, T, and E, and can be programmed to provide upscale or downscale burnout detection. In addition to the Pass/Fault/Active indicator lights, this module has an indicator light that shows a failure of a cold-junction transducer.

Thermocouple input modules are programmable to select the thermocouple type and engineering units (either Celsius or Fahrenheit). Each module can support a variety of thermocouple types, as indicated in the specifications.

Triplicated temperature transducers residing on the field termination module support cold-junction compensation. Each leg of a thermocouple module performs auto-calibration and reference-junction compensation every 5 seconds using internal voltage references. On the Model 3708EN isolated thermocouple module, a cold-junction indicator shows a failure of a cold-junction transducer. On the Model 3706AN non-isolated thermocouple module, a fault indicator shows a transducer fault.

2.1.3.7 Relay Output

The only relay output module available for safety-related use in nuclear power plants is the Model 3636TN relay output module, which has 32 normally open non-common simplex outputs. This is a non-triplicated module for use on non-critical points that are not compatible with "high-side" solid-state output switches. The Model 3636TN relay output module receives output signals from the main processors on each of the three legs. The three sets of signals are then voted, and the voted data is used to drive the 32 individual relays. Each output has a loopback circuit that verifies the operation of each relay switch, independent of the presence of a load. Ongoing diagnostics test the operational status of the relay output module, which is not intended for use on critical points or switching of field loads. In addition to the Pass/Fault/Active indicator lights, this module has indicator lights showing if each of the 32 output points is on or off.

2.1.4 Communications Modules

The communications modules of the Tricon PLC system have three separate communication buses which are controlled by three separate communication processors, one connected to each of the three main processors. All three bus interfaces merge into a single microprocessor on each communications module, so the modules lose their triple redundancy feature at this point. The microprocessor on each communications module votes on the messages from the three main processors and transfers only one of them to an attached device or external system. If two-way communication is enabled, messages received from the attached device are triplicated and transmitted to the three main processors.

The communication paths to external systems have cyclic redundancy checks (CRC), handshaking, and other protocol-based features, depending on which devices are attached to the communication modules, and how the communication modules are programmed. These features are supported in both hardware and firmware.

Three types of communications modules are available for safety-related use in nuclear power plants. Specifically, these are:

- The Model 4119AN enhanced intelligent communications module allows the Triconex PLC system to communicate with other licensee systems using a Modbus interface. The enhanced intelligent communications module contains four serial ports and one parallel port that can operate concurrently. Each serial port is uniquely addressed and supports

either the Modbus or TriStation interface. The parallel port provides a Centronics interface to a printer.

- The Model 4609N advanced communications module is an interface between the Triconex PLC system and the Foxboro Intelligent Automation Series distributed control system. The Triconex system appears as a "control processor" node on the Foxboro Intelligent Automation communication network. The advanced communications module can be configured for one-way information transmission.
- The Model 4329N network communications module allows the Triconex PLC system to communicate with other Triconex PLC systems and with external hosts over IEEE 802.3 (Ethernet) networks. This includes PCs running the TriStation programming software. The network communications module has two BNC port connectors; Net 1 supports Peer-to-Peer and time synchronization protocols, and Net 2 supports open networking to external systems using Triconex applications.

In the Model 4609N advanced communications module, the microprocessor votes on the communication messages from the three MPs and transfers only one of them to an attached external system. By contrast, the Model 4119AN enhanced intelligent communications module and the Model 4329N network communications module (NCM) use the most recent information without voting. For two-way communications, messages received from the attached external system are triplicated and transmitted to the three MPs.

By means of these communications modules, the Triconex PLC system can interface with Modbus masters and slaves, other Triconex PLC systems in peer-to-peer networks, external hosts running applications over IEEE 802.3 networks, and Honeywell and Foxboro distributed control systems. For data sent out to other systems, the main processors broadcast data to the communications modules across the communication bus. Data is typically refreshed during every scan, and is never more than two scan-times old.

As a practical matter, for safety-related applications in nuclear power plants, these modules are limited to communicating non-safety-related information from the Tricon PLC system to other plant systems, and for the TriStation 1131 programming computer to load information or programs to the Tricon PLC system. In this instance, the Model 4329N NCM would be used with the IEEE 802.3 Ethernet. The staff notes that the IEEE 802.3 protocol is by its nature not deterministic in the general case. However, the IEEE 802.3 protocol is acceptable for applications downloading because: (1) there are only two nodes on the network (the Tricon PLC system and the TriStation); (2) the PLC is off-line, and (3) a CRC check is performed to ensure that the application program has not been modified during the download operation.

2.2 Software Description

The Tricon PLC system uses three types of software, including the safety-related operating system software, the safety-related plant-specific applications programs, and the non-safety-related TriStation 1131 software used to develop and generate those application programs. The following subsections describe each of these types in greater detail.

2.2.1 Safety-Related Operating System Software Description

In the Triconex PLC system, safety-related operating system software resides in the main processor modules, I/O modules, and communications modules. All safety-related software exists permanently in electronically erasable programmable read only memory (EEPROM) and, therefore, can be considered firmware.

2.2.1.1 Main Processor Module Software

Each Triconex PLC system has three MP boards, each of which contains a separate copy of identical software. Each main processor board contains three microprocessors, the main microprocessor, the IOC, and the COM. Each of these microprocessors has different software (as shown in the following table), but each is safety-related. The main microprocessor is a 32-bit microprocessor that runs both the TSX operating environment software and the plant-specific application software. The IOC and the COM are 8-bit microprocessors that run communication-related software to control one of the external bus functions of the Tricon PLC system. Specifically, the IOC manages the I/O bus, while the COM manages the communications bus.

2.2.1.1.1 TSX Operating Environment Software

The main processor on the Model 3006N module uses TSX Version 5211 operating environment firmware, which is responsible for performing built-in self-diagnostics, managing the triple-redundancy features, and executing the application software. The operating system executes a sequence of steps in four main blocks, known as Power Up, Background, Scan Level, and Loader. A detailed description of the operating system is provided in Triconex document number 7286-535, "Software Qualification Report." The four main blocks perform the following:

- Power Up performs memory, clock, and Tribus communication tests. These functions are only performed when the system is powered up or reset, and are not performed during normal operation.
- Background performs runtime diagnostic and fault analysis functions, including microprocessor checks, verification of constants stored in RAM, checks of the I/O and communication bus interfaces, checksum checks on the application programs, and Tribus fault analysis tests.
- Scan Level obtains and votes on input data, executes the application programs, and generates outputs at the scan cycle interval set by the application programs. The input data validation checks described above are completed during this step.
- Loader processes any TriStation messages when the key switch on the main chassis is in the "remote" position.

Safety-related Software

Type	Identification	Ver.	Used in
Main Micro Processors	TSX	5211	3006N Enhanced main processor II
	IOC	5212	3006N Enhanced main processor II
	COM	5206	3006N Enhanced main processor II
Communication	ICM	4930	4119AN EICM, V9, Isolated 4329N Network Communication Module 4609N Advanced Communication Module
	ACMX	5203	4609N Advanced Communication Module
	NCMX	5028	4329N Network Communication Module
	IICX	5276	4119AN EICM, V9, Isolated
	RXM	3310	4210N Remote Extender Module, Primary 4211N Remote Extender Module, Remote
Input/Output	AI/NITC	4873	3700AN AI Module, 0-5 Vdc, 6% Overrange 3701N AI Module, 0-10 Vdc 3706AN NITC Input Module
	EIAI/ITC	5491	3703EN EAI Module, Isolated 3708EN ITC Thermocouple Input Module
	PI	4559	3510N Pulse Input Module
	EDI	5490	3501TN EDI Module, 115V ac/dc 3502EN EDI Module, 48V ac/dc 3503EN EDI Module, 24V ac/dc 3505EN EDI Module, 24 Vdc, Low Threshold
	HDI	5499	3704EN HDDI Module, 24/48 Vdc 3504EN HDAI Module, 0-5/0-10 Vdc
	EAO	5595	3805EN Analog Output Module, 4-20 mA
	EDO	5488	3601TN EDO Module, 115 Vac 3604EN EDO Module, 24 Vdc 3607EN EDO Module, 48 Vdc
	ERO	5497	3636TN ERO Module, N.O., Simplex
	TSDO	5502	3603TN EDO Module, 120 Vdc 3623N SDO Module, 120 Vdc 3624N SDO Module, 24 Vdc

The TSX software operates primarily on a continuous loop basis, and does not use a real time kernel. However, the TSX software does use some interrupts to periodically trigger execution of the application software, manage the Tribus and the Triclock mechanism and trigger the

watchdog timer. A diagnostic failure also generates an interrupt signal. The TSX software comprises about 45,000 lines of code developed in C programming language.

2.2.1.1.2 IOC Software

The IOC on the Model 3006N main processor module uses IOC version 5212 firmware which provides the interface between the main processor and the system I/O modules via the I/O bus. The IOC interchanges data with the MP using the shared RAM data structures based on the I/O module configuration.

2.2.1.1.3 COM Software

The COM on the Model 3006N main processor module uses COM version 5206 firmware, which provides an interface between the main processor and the system communications modules via the communications bus. The COM interchanges data with the MP using the shared RAM data structures based on the COM module configuration.

2.2.1.2 I/O Module Software

The Tricon PLC input modules are responsible for receiving sensor data from the attached instrumentation, manipulating the data as required, and passing the data to the IOC via the I/O bus. The output modules receive data from the IOC via the I/O bus, convert it as required, and pass it on to the connected output devices.

On each I/O module the firmware is replicated on each of the three legs, for use by the three leg-specific microprocessors, which exchange diagnostic data but not field data. The I/O modules do not contain plant-specific application software; however, an I/O module can be dedicated to a specific use in a plant-specific system by setting the parameters within this firmware. The firmware of the input modules continuously polls the input points from the field sensors and updates the input database for its own leg. The firmware of the output modules continuously reads the output data provided by the main processor and updates the output registers of its own leg.

In both the input and output modules, the firmware is responsible for performing self diagnostics and handling communication with the main processor via each leg's individual I/O bus. This bus is a serial bus, and the I/O modules operate as slaves responding to requests from the master main processor board.

The I/O data is continuously updated using an infinite loop that also runs diagnostics. Communication with the main processors is performed via interrupts from the I/O processor.

Even though each type of I/O module has its own specific firmware, all I/O modules have the same basic design and share common parts of the source code. The code was originally written in assembly language and is now progressively being replaced by C code. All I/O modules have both software and hardware watchdog timers to monitor and verify bus and module activity.

The staff reviewed the following I/O module firmware:

- AI/NITC version 4873, used in: 3700AN AI Module, 0-5 Vdc
3701N AI Module, 0-10 Vdc
3706AN NITC Input Module

This firmware converts analog input voltage signals to digital values and transmits the values to the IOC on demand. Automatic calibration is performed on the analog-to-digital converters. For the Model 3706AN thermocouple module, linearization of the selected thermocouple type and cold junction compensation are performed and the resultant temperature is passed to the IOC.

- EIAI/ITC version 5491, used in: 3703EN EAI Module
3708EN ITC Thermocouple Input Module

This firmware converts the analog input voltage signals to digital values and transmits the values to the IOC on demand. Automatic calibration is performed on the analog-to-digital converters.

- PI version 4559, used in: 3510N Pulse Input Module

This firmware counts voltage transitions during a time window, converts the raw counts to either frequency or revolutions per minute (RPM), and transmits the values to the IOC on demand.

- EDI version 5490, used in: 3501TN EDI Module, 115Vac/dc
3502EN EDI Module, 48Vac/dc
3503EN EDI Module, 24Vac/dc
3505EN EDI Module, 24 Vdc, Low-Threshold

This firmware converts the input voltage signals to digital values and transmits the values to the IOC on demand. The inputs are transmitted using optical isolation circuitry. For the Model 3502EN and 3505EN, the module can perform a self-test to check for conditions where the input circuitry is "stuck on."

- HDI version 5499, used in: 3704EN HDDI Module, 24/48 Vdc (24V)
3504EN HDAI Module, 0-5/0-10 Vdc

This firmware converts the isolated, variable analog input voltage signals to digital values and transmits the values to the IOC on demand.

- EAO version 5595, used in: 3805EN Analog Output Module, 4-20 mA

This firmware receives data from the IOC, performs a digital-to-analog conversion, and votes on which of the three hardware channels is to be provided to the single output point. Each output is checked for accuracy, and any of the three outputs that fail(s) to produce the correct current output value is replaced.

- EDO version 5488, used in: 3601TN EDO Module, 115 Vac
3604EN EDO Module, 24 Vdc
3607EN EDO Module, 48 Vdc

This firmware receives data from the IOC and outputs data to the output switches. A quadruplicated voter exists on each output point. The output of the voter is then provided to the field devices. The voltage on each output is checked, independently of any attached load. Failure of the detected field voltage to match the commanded state is considered an error and annunciated. Additional diagnostics are performed on the module.

- ERO version 5497, used in: 3636TN ERO Module, N.O., Simplex

This firmware receives data from the IOC, votes on it, and outputs it to the individual relays. Each output has a loopback circuit, which does not depend on the presence of a load. This loopback feature is used by diagnostics to test the operational status of the module.

- TSDO version 5502, used in: 3603TN EDO Module, 120 Vdc
3623N SDO Module, 120 Vdc
3624N SDO Module, 24 Vdc

This firmware receives data from the IOC and outputs data to the output switches. A quadruplicated voter on each output point provides its output to the field devices. The voltage on each output is checked, independent of any attached load. The current flowing through the output switch is also checked. Diagnostics are provided to verify the operation of each element in the output voter and the presence of a load.

2.2.1.3 Communications Module Software

The firmware in the Tricon PLC communications modules is somewhat different from that in the I/O modules in that each module has two types of firmware, one that is common to all three communications modules, and the one that is module-specific. The staff reviewed the following communications module firmware:

- ICM version 4930, used in: 4609N Advanced Communication Module
4119AN EICM, Isolated
4329N Network Communication Module

This firmware is common to all communications modules. It provides the interface to the triplicated communication buses, votes on output messages, and replicates the input messages to the three communication buses. It also includes common module diagnostics.

- ACMX version 5203, used in: 4609N Advanced Communication Module

This firmware provides the Triconex-generated portion of the software that is needed for module hardware interfaces and communication protocols required to communicate with

the Foxboro Intelligent Automation (I/A) system and the TriStation 1131. This firmware also provides the diagnostic interfaces to the module-specific hardware.

- NCMX version 5028, used in: 4329N Network Communication Module

This firmware provides the module hardware interfaces and communication protocols required for peer-to-peer communication and time synchronization with other Tricon PLC systems, with external hosts over IEEE 802.3 Ethernet networks, and with the TriStation 1131. This firmware also provides the diagnostic interfaces to the module-specific hardware.

- IICX version 5276, used in: 4119AN EICM, V9, Isolated

This firmware provides the module hardware interfaces and communication protocols required to communicate with Modbus masters and slaves, as well as printers. This firmware also provides the diagnostic interfaces to the module-specific hardware.

Except when downloading application software or updating parameters such as setpoints, a plant system built with a Tricon PLC does not need or use these communications modules or features to perform safety-related functions.

A special case of communications module firmware is used by the primary and remote extender modules. This firmware, RXM version 3310, is used by both the 4210N Remote Extender Module and the 4211N Remote Extender Module. This firmware allows extending the copper I/O Bus over extended distances.

2.2.2 Safety-Related Plant-Specific Application Software

The plant-specific application software implements the desired safety-related functions. This software is developed on a PC with the TriStation 1131 Developers Workbench (discussed in Section 2.2.3) and downloaded to the main processor boards. The application software consists of a sequence of calls to the basic functions that are available on libraries stored in the TriStation 1131. Those basic functions that are used by the applications programs are downloaded to the main processor boards along with the application software. As this software is plant specific (not generic) in nature, the staff did not review or approve any applications programs. Plant-specific reviews will be required for approval of applications software.

2.2.3 TriStation 1131 Software

The TriStation 1131 Developers Workbench is a software tool designed to generate the plant-specific application programs. The software runs on a standard commercial PC using the Windows NT operating system. The TriStation 1131 Developers Workbench does not perform safety-related functions, but allows the user to generate safety-related software for the Tricon PLC. The TriStation 1131 PC is not normally connected while the Tricon PLC system is running safety-critical functions. The only time that the TriStation PC and TriStation 1131 should be connected to the safety-related system is while new or modified programs are being downloaded to the Tricon PLC system. (It is physically possible for the TriStation PC to be connected at other times, and this should be prevented via administrative control.)

The TriStation 1131 Developers Workbench can use any one of four programming languages. Specifically, these are Structured Text, Function Block Diagrams, and Logic Diagrams, as well as the Triconex-defined Cause-and-Effect Matrix Language (CEMPLE). The first three of these programming languages conform to the requirements of the International Electrotechnical Commission (IEC) Standard 61131-3, "Programming Languages," dated 1993. The Developers Workbench uses a graphical user interface, and has language editors; compilers; linkers; emulation, communication, and diagnostic capabilities for the Tricon PLC system.

The TriStation 1131 Developers Workbench translates the program written in one of the four languages into native mode executable code. Logic Diagrams, Function Block Diagrams, and CEMPLE are translated into Structured Text. The Structured Text is then translated into an emulated code, which can in turn be translated into native mode assembly language. The assembly language code is then assembled and linked with native mode code libraries to generate an executable program. Up to this point, all application development may be performed off line, with no physical connection between the TriStation PC and the Tricon PLC system. After the executable program is tested and verified, the TriStation PC can be attached to the Tricon PLC system, and the executable application program can be downloaded to the PLC via the NCM module.

During the download process, the individual communication blocks of programs and translated code are protected by 32-bit CRC and communication blocks are rejected if the CRC fails to match. In addition, program segments (which may span communication blocks) have an overall 32-bit CRC. The 32-bit CRC for each program is stored both in the TriStation and in the Tricon PLC system.

The TriStation 1131 Developers Workbench has the ability to emulate a given applications program running on the Tricon PLC system. This emulation allows manual input of program variables and observation of program outputs on the PC screen, with the input and output values merged and displayed with the program blocks. This emulation can be used in the validation of new or modified application code.

These features of the TriStation 1131 Developers Workbench enable the developer to perform the following tasks:

- Develop programs and other executable elements (such as functions, function blocks, data types) using any of the available language editors.
- Select functions and function blocks from the IEC-compliant libraries and/or custom libraries.
- Graphically configure the I/O modules and points for each chassis in a Tricon PLC system.
- Configure a Tricon PLC system to use the integrated sequence of events (SOE) capability.
- Apply password protection to projects and programs according to user names and security levels.

- Debug program logic by emulating execution.
- Download the newly created applications programs to the Tricon PLC system.
- Display diagnostic information about system performance and fault details.

2.3 Tricon PLC Product Qualifications

The Tricon PLC hardware is qualified for a mild environment, such as a main control room and auxiliary electrical equipment rooms. Triconex performed pre-qualification, environmental, seismic, electro magnetic interference/radio frequency interference (EMI/RFI), surge withstand, and Class 1E to non-1E isolation tests; these tests were performed in the listed order and in accordance with the requirements of EPRI TR-107330. A test system (as described below) was assembled and used for all tests; this system was reconfigured as necessary to support the protocol and worst-case loading scenario for each test.

The Tricon PLC test system contained the following components for which Triconex has requested qualification for safety-related use in nuclear power plants:

- 19-inch Chassis, Models 8110 (Main), 8111 (Expansion), and 8112 (Remote Expansion)
- Power Modules, Models 8310 (115 V), 8311 (24 Vdc), and 8312 (230 Vac)
- Main Processor Module, Model 3606
- Analog Input Modules, Models 3700A, 3701, 3703E, and 3704E
- Digital Input Modules, Models 3501E, 3502E, 3503E, 3504E, and 3505E
- Pulse Input Module, Model 3510
- Thermocouple Input Modules, Models 3706A, and 3708E
- Analog Output Module, Model 3805E
- Digital Output Modules, Models 3601E, 3603E, 3603T, 3604E, 3607E, 3611E, 3623, and 3624
- Relay Output Module, Model 3636R
- Remote Extender Modules, Models 4210, and 4211
- Communications Modules, Models 4119A, 4329, and 4609

The test system also included various ETAs, signal and communication cables, an RTD input signal conditioning panel, and a third-party 24 Vdc field power supply (Lambda Model LNS-P-24).

2.3.1 Environmental Requirements

The objective of the environmental testing was to demonstrate that the Tricon PLC will not experience failures due to abnormal service conditions of temperature, humidity, power source variation, or radiation. EPRI TR-107330, section 4.3, provides the environmental requirements for commercial PLC equipment.

Criteria for environmental qualifications of safety-related equipment are provided in General Design Criterion (GDC) 2, "Design Bases for Protection Against Natural Phenomena," and GDC 4, "Environmental and Dynamic Effects Design Bases," as specified in Appendix A to 10 CFR Part 50. The staff conducted its reviews in accordance with the guidance provided in Appendix

7.1-A to NUREG-0800, the NRC's Standard Review Plan (SRP) Revision 4, dated June 1997, which references Appendix 7.1-B, item 5, and Appendix 7.1-C, item 9. These two items reference American National Standards Institute (ANSI)/IEEE Std 323-1974, "IEEE Standard for Qualifying Class 1E Equipment for Nuclear Power Generating Stations," and EPRI TR-102323, "Guidelines for Electromagnetic Interference Testing in Power Plants," dated January 1997.

2.3.2 EMI/RFI Requirements

Section 4.3.7 of EPRI TR-107330 states that PLC systems shall be able to withstand the EMI/RFI levels as given in EPRI TR-102323.

2.3.3 Electrostatic Discharge (ESD) Withstand Requirements

Section 4.3.8 of EPRI TR-107330 requires that when installed in its chassis, the PLC platform and associated devices shall have the capability to withstand ESD as required by EPRI TR-102323 without disrupting operation or causing any damage.

2.3.4 Seismic Withstand Requirements

Section 4.3.9 of EPRI TR-107330 requires that the PLC platform must be qualified as a Category I seismic device, and therefore must perform as required and remain operational for the specified level of vibration during and following the application of a safe shutdown earthquake applied in three orthogonal directions.

2.3.5 Surge Withstand Requirements

Section 4.6.2 of EPRI TR-107330 requires that the PLC platform be capable of withstanding surges with a characteristic of both the standard 0.5 μ s-100 kHz ring wave and the standard 1.2/50 μ s-8/20 μ s combination wave described in IEEE C62.41. The withstand level shall be consistent with Section 9 of IEEE C62.41 for location "B" and "medium exposure" except that the applied voltage shall be 3,000 V peak. The testing requirements are shown in Section 6.3.5 of EPRI TR-107330. Additional requirements are found in EPRI TR-102323.

2.3.6 Class 1E to Non-1E Isolation Requirements

Section 4.6.4 of EPRI TR-107330 provides the Class 1E to Non-1E isolation requirements, stating that the PLC modules must provide an isolation capability of at least 600 Vac and 250 Vdc applied for 30 seconds. Additional requirements are provided in IEEE Std 384-1977, "Criteria for Independence of Class 1E Equipment and Circuits."

3.0 REVIEW CRITERIA

The acceptance criteria for this review is defined in NUREG-0800, the NRC's SRP, Revision 4, dated June 1997. The subsections below will list which portions of 10 CFR Part 50, general industry standards, Branch Technical Positions (BTPs), and other guidance used in this review, as well as the methodology used when conducting this review.

3.1 General Standards

The staff performed this review using the acceptance criteria defined in NUREG-0800, the NRC's SRP, Revision 4, dated June 1997. Specifically, Section 7 of the SRP addresses the requirements for instrumentation and control (I&C) systems in light-water nuclear power plants. Revision 4 is particularly notable, in that it refined the procedures for reviewing digital systems, which principally appear in SRP Appendices 7.0-A, 7.1-A; Sections 7.1, 7.8, 7.9; and BTPs HICB-14, HICB-17, HICB-18, HICB-19, and HICB-21. SRP Appendix 7.1-C and Sections 7.2 through 7.7 provide additional criteria that the staff applied in the review of the appendices to Triconex's topical report.

Because the Tricon PLC system is a commercial, off-the-shelf (COTS) PLC system, two EPRI documents apply. The first is EPRI TR-106439, "Guideline on Evaluation and Acceptance of Commercial-grade Digital Equipment for Nuclear Safety Applications," dated October 1996, reviewed by the staff and approved in a safety evaluation report (SER) dated April 1997. The second document is EPRI TR-107330, "Generic Requirements Specification for Qualifying a Commercially Available PLC for Safety-Related Application in Nuclear Power Plants," which the staff approved on July 30, 1998. Triconex has stated that its submittals follow the guidance of both of these documents.

SRP Table 7-1 lists a number of codes and standards that apply to the review of digital I&C systems. Many of these deal with plant-specific requirements and, therefore, cannot be addressed in the review of a generic topical report. These plant-specific requirements were not considered in performing this safety evaluation, but will be subject to the reviews of future plant-specific applications when submitted by licensees. Many of the other codes and standards listed in SRP Table 7-1 assume that the equipment and systems to be evaluated are specifically designed as nuclear safety-related equipment in accordance with Appendix B of 10 CFR Part 50. This was not the case for the Tricon PLC system. For this reason, these codes and standards were used as guidance during the review of the Tricon PLC system, but not as absolute requirements. The overriding criterion for this review was that in the case where the methods and techniques used by Triconex were not identical to the approved methodology, those methods and techniques were of sufficient quality to provide the staff with reasonable assurance that the quality and operability of the Tricon PLC are suitable for safety-related use in nuclear power plants.

Specifically, the staff considered the following codes and standards, and used them as a yardstick against which to measure the Triconex design effort and the Tricon PLC system when reaching this determination of suitability:

- 10 CFR 50.55a(a)(1)

- 10 CFR 50.55a(h)
- 10 CFR 50, Appendix A, GDC as follows:
 - GDC 1, Quality Standards and Records
 - GDC 2, Design Basis for Protection Against Natural Phenomena
 - GDC 4, Environmental and Missile Design Bases
 - GDC 13, Instrumentation and Control
 - GDC 20, Protection System Functions
 - GDC 21, Protection System Reliability and Testability
 - GDC 22, Protection System Independence
 - GDC 23, Protection System Failure Modes
 - GDC 24, Separation of Protection and Control Systems
 - GDC 29, Protection Against Anticipated Operational Occurrences
- RG 1.22, "Periodic Testing of Protection System Actuation Functions"
- RG 1.47, "Bypassed and Inoperable Status Indication for Nuclear Power Plant Safety Systems"
- RG 1.53, "Application of the Single-Failure Criterion to Nuclear Power Plant Protection Systems"
- RG 1.62, "Manual Initiation of Protection Actions"
- RG 1.75, "Physical Independence of Electrical Systems"
- RG 1.89, "Qualification for Class 1E Equipment for Nuclear Power Plants"
- RG 1.97, "Instrumentation for Light-Water-Cooled Nuclear Power Plants to Assess Plant and Environs Conditions During and Following an Accident"
- RG 1.100, "Seismic Qualification of Electric and Mechanical Equipment for Nuclear Power Plants"
- RG1.105, "Instrument Spans and Setpoints"
- RG 1.118, "Periodic Testing of Electric Power and Protection Systems"
- RG 1.152, "Criteria for Digital Computers in Safety Systems of Nuclear Power Plants"
- RG 1.153, "Criteria for Power Instrumentation and Control Portions of Safety Systems"
- RG 1.168, "Verification, Validation, Reviews and Audits for Digital Computer Software Used in Safety Systems of Nuclear Power Plants"
- RG 1.169, "Configuration Management Plans for Digital Computer Software Used in Safety Systems of Nuclear Power Plants"

- RG 1.170, "Software Test Documentation for Digital Computer Software Used in Safety Systems of Nuclear Power Plants"
- RG 1.171, "Software Unit Testing for Digital Computer Software Used in Safety Systems of Nuclear Power Plants"
- RG 1.172, "Software Requirements Specification for Digital Computer Software Used in Safety Systems of Nuclear Power Plants"
- RG 1.173, "Developing Software Life Cycle Processes for Digital Computer Software Used in Safety Systems of Nuclear Power Plants"

3.2 Method of Review

In addition to reviewing Triconex's topical report, the staff held several public meetings at NRC and at MPR Associates in Alexandria, Virginia. The staff also conducted an audit on February 12-15, 2001, at the Triconex design and manufacturing site in Irvine, California, to discuss various aspects of the Tricon PLC design. These meetings successfully yielded answers to the staff's questions, making it unnecessary for the staff to request additional information.

The suitability of a digital platform for use in safety systems depends on the quality of its components; design quality; and system implementation aspects such as real-time performance, independence, and online testing. Section 4 of this safety evaluation discusses the staff's review of these system implementation aspects and the quality of the Tricon PLC platform components.

The acceptance process for most commercial-grade digital components typically comprises a variety of complicated technical activities. Consequently, the staff applied the guidance in EPRI TR-106439 and TR-107330 in reviewing the Triconex program for qualifying the Tricon PLC hardware and software. In evaluating the Tricon PLC platform for use in safety-related applications in a nuclear power plant, the staff reviewed (1) the hardware design, (2) the firmware and programming software design, (3) the qualification testing, (4) the qualification analyses, and (5) the history of commercial use of the Tricon PLC system. At this stage, the staff was looking programmatically at the design process and making comparisons to the applicable review guidance. The staff also reviewed the specific verification and validation performed on the software by the German Technischer Überwachungs-Verein (TÜV) Rheinland, and the critical design review performed by MPR Associates and ProDesCon. In addition, the staff performed a "thread audit," which involved selecting samples of assumed plant parameters and tracing the implementation of those parameters through the hardware and software. This review included evaluating actual sections of the code on a sample basis, and following the signal path through the hardware circuitry.

4.0 EVALUATION

Triconex designed and built the Tricon PLC system as a commercial-grade system, rather than specifically for use in safety-related systems in nuclear power plants. As a result, the design process was not governed by Appendix B to 10 CFR Part 50, and the related process documentation is not consistent with BTP HICB-14. EPRI TR-106439 and TR-107330 recognize that commercial design practices differ from nuclear specific design practices, and discuss how the essential technical characteristics of commercial PLC and digital system products meet the requirements, intent and quality characteristics needed for safety-related systems in nuclear power plants.

The Tricon PLC system design has evolved into a mature product over more than 15 years, and Triconex's software quality assurance (QA) program has also improved significantly over that period. The current QA program satisfies the provisions established by BTP HICB-14. In addition, Triconex has developed the TriStation 1131 Developers Workbench for engineering support and programming of the Tricon PLC system over the past 7 years, under a process that is compatible with the intent of BTP HICB-14.

4.1 Tricon PLC Hardware Design Review

The review of the Tricon PLC system hardware design included the hardware architecture and signal flow, quality provisions for the hardware, and the environmental testing and qualification methodology and results.

4.1.1 Hardware Architecture and Signal Flow

The staff reviewed the Tricon PLC hardware design, as well as the signal flow through that design. The Tricon PLC system uses a triple-redundant architecture to provide fault tolerance and uninterrupted control in the presence of either hard failures of components or transient faults from internal or external sources. Sensor signals are received on termination assemblies, which are constructed as electrically passive circuit boards to which field wiring is attached. The termination module passes input signals from the field to an input module. Each input module consists of three identical and independent circuits, all contained on a single printed circuit assembly. Each of the three input legs asynchronously measures the input signals from the input termination module and places the values into input tables. Each input table is regularly interrogated over the I/O bus by the I/O communication processor which is located on the corresponding main processor module.

As each input module is polled, the appropriate leg of the I/O bus transmits new input data to the main processor, where it is assembled into a table that is stored in memory for use in the hardware voting process. The input table in each main processor is transferred to its neighboring main processors over the Tribus. Hardware voting takes place during this transfer. The Tribus uses direct memory access to synchronize, transmit, vote, and compare data among the three main processors. If a disagreement occurs, the signal value found in two out of three tables prevails, and the third table is corrected accordingly. One-time differences that result from sample timing variations are distinguished from a pattern of differing data. Each main processor maintains data about necessary corrections in local memory. Any disparity is

flagged and used at the end of the scan by the built-in fault analyzer routines of the Tricon PLC system to determine whether a fault exists on a particular module.

The main processors enter corrected data into the control program, which the main microprocessor and a math coprocessor execute in parallel with the neighboring main processor modules. The control program generates trip or control signals on the basis of licensee specific application programs. The I/O communication processor on each main processor module sends the output data to output modules via the I/O bus. In the event of a trip signal, the output modules use termination assemblies to transfer the trip signal to the actuation devices.

If an I/O module channel fails to function, an alarm is raised to the MPs. If a redundant module is installed in the paired slot with the faulty module, and that module is deemed healthy by the MPs, the system automatically switches over to the standby unit and takes the faulty module off line. If no standby unit is in place, the faulty module continues to operate on two of the three legs, and control is unaffected. The user obtains a replacement unit and plugs it into the system in the paired slot associated with the failed module. (This position is logically paired with the failed module's location.) When the MPs detect the presence of a replacement module, they initiate local health state diagnostics and, if the module is healthy, automatically switch over to the new module. The user then removes the faulty module for repair or replacement.

If redundant modules are installed and both are deemed healthy by the MPs, the MPs will swap control between the redundant modules so that each is used on a periodic basis. By periodically using each module, any faults will be detected and alarmed, and the failed module will be replaced while a redundant module is in place. This use of redundant modules does not cause process upsets, and is undetectable outside of the Tricon PLC system.

The staff finds that the design is suitable for use in nuclear power plants when appropriately implemented.

4.1.2 Hardware Quality

The Tricon PLC system was initially developed in 1986. The vendor, Triconex, states that it uses good practices consistent with the objective of producing a highly reliable safety system, and the first Triconex QA Manual was developed in 1986 on the basis of the requirements established in the standard formerly titled American Society of Mechanical Engineers "Quality Assurance Program Requirements for Nuclear Facilities," NQA-1. In addition, Triconex has specifically developed all quality-related manuals and procedures for the Tricon PLC system. Specifically, the following manuals that describe the processes and procedures for the various aspects of the Tricon PLC system manufacture were reviewed as part of the staff audit:

- Triconex Quality Assurance Manual (QAM)
- Triconex Quality Procedures Manual (QPM)
- Triconex Engineering Department Manual (EDM).

The QAM provides the overall corporate QA requirements for the Tricon PLC system, including specific procedures for the Triconex QA organization. The first revision of the QPM, in 1992, contained procedures specific to manufacturing activities, while the 1994 revision included procedures specific to product development. The EDM provides the procedures pertinent to the development, configuration control, maintenance, and modification of the Tricon PLC system.

The QAM requires that all materials and services that are incorporated into or directly related to Triconex products must be procured from approved vendors. Potential vendors are assessed by the Vendor Assessment Team (VAT) on the basis of the vendor's responses to a questionnaire. The VAT may also perform a follow-up in-depth audit and/or a vendor site survey to evaluate the vendors' manufacturing and QA capabilities. The Quality Assurance Review Board then makes the final decision regarding vendor approval, and Purchasing and Manufacturing maintains a list of approved vendors. Nuclear vendors are evaluated and audited to verify their capability to meet the QA requirements of Appendix B to 10 CFR Part 50.

Two other documents are part of the Triconex QA system. The Triconex General Manual (TGM) requires that critical characteristics of the parts be identified. The Invensys Process System (IPS) is used to document the engineering evaluation of commercially procured items, and an evaluation must consider the item's intended use, its safety-related function, its traceability requirements, and its critical characteristics. The acceptance of any IPS item is contingent on verification of the critical characteristics. The method of acceptance may include: (1) source inspection and/or special testing as part of the receiving inspection, (2) a certificate of conformance, (3) pre-established tests or checks as part of installation or integration, and/or (4) evaluation of historical performance. For nuclear parts, TGM D-4 notes that historical performance cannot be used as the sole basis for acceptance.

The purchasing data for nuclear safety-related equipment and services are to be so identified, and must include a vendor QA program meeting the criteria of Appendix B to 10 CFR Part 50 and 10 CFR Part 21. Purchasing records consisting of (1) vendor approval documentation, (2) vendor audit reports, (3) the approved vendor list, (4) the approved material list, (5) source inspection reports, (6) first article inspection reports, (7) purchase orders, and (8) the IPS are assigned to responsible departments in the Triconex organization.

Triconex procures the commercial-grade items used in the Tricon PLC platform from various commercial-grade vendors. As part of the commercial-grade dedication (CGD) of these items, Triconex teams conducted reviews at the vendors' facilities to assess the quality of the vendors' activities. These reviews focused on the vendors' hardware and software life cycle with regard to the following:

- well-defined system hardware and software requirements;
- comprehensive hardware and software development methodologies;
- comprehensive test procedures;
- strict configuration management and maintenance procedures; and
- complete and comprehensive documentation.

The findings of the Triconex review teams were documented in Triconex proprietary reports and records which the staff reviewed as part of its hardware QA audit.

On the basis of its review of the manuals and audit of the Triconex facility and manuals with its walkthrough of purchasing and parts quality, the staff concludes that the quality of the Tricon PLC platform components is adequate for safety-related use in nuclear power plants.

4.1.3 Environmental Testing and Qualification

To comply with the requirements of GDC-4, 10 CFR 50.49, and IEEE Std 279-1971, "Criteria for Protection Systems for Nuclear Power Generating Stations," or IEEE Std 603-1991, "IEEE Standard Criteria for Safety Systems for Nuclear Power Generating Stations," environmental qualification must demonstrate that the design basis and performance requirements of the I&C system are met when the equipment is exposed to normal and adverse environments. The subsections below will discuss the staff review of the Tricon PLC system environmental testing performed by Triconex.

4.1.3.1 Pre-qualification Testing

Triconex performed pre-qualification testing to (1) confirm that the Tricon PLC test system was properly configured and operational, (2) provide baseline performance data for comparison with data obtained during and after qualification testing, and (3) validate the test procedures.

Pre-qualification testing included the following assessments:

- The system setup and checkout test documented proper configuration and operation of the Tricon PLC test system, including hardware, software, input and output simulators; test and measurement equipment; and interconnecting cabling.
- The operability test to establish baseline performance included tests for analog module accuracy, system response time, operation of discrete inputs and outputs, performance of timer functions, failover tests (associated with the failure of redundant components), loss of power, detection of failure to complete a scan, power interruption, and power quality tolerance.
- Prudency testing demonstrated the ability of the Tricon PLC system test system to operate within specifications under dynamic conditions. The prudency test included a burst of events test, a serial port receiver failure test, and a serial port noise test.

Triconex performed these pre-qualification tests in accordance with Section 5.2 of EPRI TR-107330, with two exceptions. Specifically, Triconex did not test the software objects in the PLC library. (The topical report justifies this exception by taking credit for the extensive software object testing that was previously performed by Triconex and TÜV Rheinland.) Also, Triconex performed only limited burn-in testing. (The topical report justifies this exception by taking credit for routine burn-in testing that is performed as part of the manufacturing process for the Tricon PLC system hardware.) Details of the testing can be found in the following Triconex documents:

<u>Document Title</u>	<u>Triconex Document Number</u>
Set-up & Checkout Test Procedure	7286-502
Operability Test Procedure	7286-503
TSAP Validation Test Procedure	7286-513
TSAP Functional Specification	7286-517
TSAP Design Specification	7286-518
TSAP Program Listing	7286-519
Pre-Qualification Test Report	7286-524

The staff concluded, after reviewing these documents, that the pre-qualification testing met the intent of TR-107330.

4.1.3.2 Temperature and Humidity Testing

Triconex performed environmental tests as identified in Section 6.3.3 of EPRI TR-107330 to demonstrate that the Tricon PLC system will not experience failures as a result of abnormal service conditions of temperature and humidity. Specifically, the Tricon PLC system was required to operate under the environmental conditions defined in Section 4.3.6 of EPRI TR-107330, as follows:

The operating environment where the PLC must meet the performance requirements given in Sections 4.3.2 through 4.3.4 are as follows:

- A. *Temperature Range. The PLC shall remain operable over an ambient temperature of 16 to 40°C (60 to 104°F) near the fan inlet if forced circulation is used or at the bottom of the chassis if natural circulation cooling is used.*
- B. *Humidity. The PLC must operate over a 40 to 95% (non-condensing) relative humidity range.*
- C. *Power Sources. The PLC must operate within specification for the power source ranges given in items A and B of Section 4.6.1.1.*
- D. *Radiation. The PLC must operate within specification for radiation exposure of up to 10³ rads.*

The abnormal operating environment where the PLC must meet the performance requirements given in Sections 4.3.2 through 4.3.4 are as follows:

- A. *Temperature Range. The PLC shall remain operable over an ambient temperature of 4 to 50°C (40 to 120°F) near the fan inlet if forced circulation is used or at the bottom of the chassis if natural circulation cooling is used.*
- B. *Humidity. The PLC must operate over a 10 to 95% (non-condensing) relative humidity range.*

- C. Power Sources. *The PLC must operate within specification for the power source ranges given in items A and B of Section 4.6.1.1.*
- D. Radiation. *The PLC must operate within specification for radiation exposure of up to 10^3 rads.*

The PLC shall operate for the temperature/humidity environmental profile given in Figure 4-4 with operability as given in Section 5.3. Evaluations, which provide confidence that none of the components in the PLC platform are degraded by exposure to the radiation level given in the previous section, are adequate for establishing radiation withstand capability.

Triconex performed the temperature and humidity tests using the Tricon PLC test system described in Section 2.3 of this SE and documented the test procedures and results in the "Environmental Test Procedure," document number 7286-506 and in the "Environmental Test Report," document number 7286-525. The test system was configured to maximize internal heat generation, power supply loading, and module point loading during the tests. At least one point on each input/output module was monitored for proper operation during testing. Communications modules were exercised through the interface with external monitoring devices. The third-party field power supply was loaded to 90 percent rated current output and monitored for output voltage variations. Operability and prudency testing was repeated several times during testing and one time after testing to demonstrate that throughout the testing, the Tricon PLC system was operating acceptably. The Triconex topical report stated that, in accordance with Section 5.9.8 of IEEE 381-1977, replacement of faulted or failed modules using spare modules constituted replacement with a similar test component, and allowed continuation of the test from the point of replacement.

Although the relative humidity at the low-temperature condition was not established because of a malfunction in the measuring equipment, the actual moisture content in the test chamber environment at the low-temperature condition was substantially lower than that at the high temperature condition. Accordingly, the test achieved the objective of exposing the tested equipment to a wide range of humidity conditions.

Two hardware faults occurred during the environmental qualification testing of the Tricon PLC system, however, because of the fault tolerant system design, these faults did not affect the expected operation of the system. Specifically, the Model 3603E 120 Vdc digital output module showed a voter fault diagnostic, and the Model 3611E 115 Vac digital output module showed a diagnostic fault message. Both of these faults resulted from component failures. During the environmental testing, Triconex replaced the Model 3603E 120 Vdc digital output module with a spare module, and that spare demonstrated acceptable performance during the remainder of the test. By contrast, on the basis of the post-test inspection results, Triconex withdrew the Model 3611E module from consideration for nuclear safety-related application; therefore the topical report does not list the Model 3611E as one of the modules for which Triconex requested approval. The Model 3601TN provides comparable functionality to the Model 3611E and demonstrated acceptable performance during environmental testing.

By subjecting the test system to a controlled temperature and humidity for the specified time profile and monitoring the performance of the test specimen, these tests demonstrated that the

Tricon PLC system hardware and third party field power supply will function under abnormal temperature and humidity conditions. However, these tests did not demonstrate that the Tricon PLC system is suitable for any particular plant usage, and plant-specific assessment of the suitability of the Tricon PLC system for an application is the responsibility of the licensee.

4.1.3.3 Radiation Withstand Testing

Triconex conducted an analysis to demonstrate that the Tricon PLC system hardware will continue to perform its safety-related function after a cumulative radiation exposure of 1000 rads over a 40-year operating period. This analysis is contained in Triconex Report No. 7286-533, "Radiation Hardness Evaluation." The level of exposure is consistent with installation in a "mild environment" as specified in Section 4.3.6 of EPRI TR-107330. On the basis of that analysis, the staff concludes that the Tricon PLC system hardware is qualified to the radiation exposure levels specified in Section 4.4 of EPRI Technical Report 1000799; however, before installing plant-specific Tricon PLC system equipment, licensees will need to verify that the expected radiation exposure for the equipment is enveloped by the radiation withstand capacity of the Tricon PLC system equipment. In addition, the staff notes that the Triconex analysis did not address the radiation withstand capability of the third-party field power supply. Therefore, the staff finds that before installing the third-party field power supply, a licensee needs to demonstrate the power supply is capable of withstanding the radiation exposure expected in the intended application.

4.1.3.4 Seismic Withstand Testing

To demonstrate that the Tricon PLC system hardware and third-party field power supply will function under seismic motion conditions, Triconex subjected the test system to a series of seismic simulation tests using a triaxial seismic simulator shake table. These tests included resonance search tests and random triaxial multifrequency tests designed to simulate a series of earthquake motions, as specified in IEEE Std 344-1987. The testing is required to include a resonance search followed by five simulated operating basis earthquakes and one simulated safe shutdown earthquake (SSE) at 9.75 g's and 14 g's respectively, based on 5 percent damping. The simulation vibrations are required to be applied triaxially (in three orthogonal directions), with random frequency content. Triconex documented these tests in the "Seismic Test Procedure," Triconex document number 7286-507 and in the "Seismic Test Report," Triconex document number 7286-526.

Triconex configured the chassis to represent lightly loaded to fully loaded module fill conditions. At least one point on each I/O module was monitored for proper operation during testing. A portion of the digital output module points were loaded to rated current carrying capacity and were cycled during testing to demonstrate continued operability. Mechanical relay output points were monitored for contact bounce. Communications modules were exercised through interface with external monitoring devices. The third-party field power supply was loaded to 90 percent rated current output and monitored for voltage and frequency variations. Operability and prudency testing was performed following seismic testing to demonstrate acceptable operation.

With one exception, seismic testing demonstrated that the Tricon PLC equipment can withstand the cumulative effects of a minimum of five operating-basis earthquakes, followed by a safe

shutdown earthquake, without loss of either safety function or physical integrity. The exception is to the maximum acceleration force of the SSE. The acceleration capability of the Triaxial Seismic Simulator Table was limited to a maximum of 10 g's based on 5 percent damping with the equipment tested, and therefore SSE tests were performed using a maximum acceleration level of 10 g's. Seismic testing was performed in accordance with IEEE Std 344-1987 and Section 6.3.4 of EPRI TR-107330.

On the basis of this review, the staff concludes that the tested Tricon PLC system equipment and third-party field power supply are qualified to the triaxial seismic simulator table limits shown in Figure 4-2 of EPRI Technical Report 1000799, with the exception of the maximum acceleration of an SSE. For this reason the staff finds that the Tricon PLC system did not fully meet the requirements of EPRI TR-107330 for seismic requirements, and before using Tricon PLC system equipment in safety-related systems in a nuclear power plant, licensees must determine that the plant-specific seismic requirements are enveloped by the capabilities of the Tricon PLC system. This determination, and the suitability of the Tricon PLC system for a particular plant and application is the responsibility of the licensee.

4.1.3.5 Electromagnetic Compatibility Testing

In order to simplify the plant-specific determination of electromagnetic compatibility, EPRI submitted Topical Report TR-102323, "Guideline for Electromagnetic Interference Testing in Power Plants" for staff review in 1994. That report provided alternatives to performing site-specific EMI surveys to qualify digital plant safety I&C equipment in a plant's electromagnetic environment. Specifically, the recommended alternatives in TR-102323 include (1) a set of EMI/RFI susceptibility testing levels, (2) EMI eliminating practices, and (3) equipment EMI/RFI emission testing levels. In 1996, the NRC staff issued a safety evaluation concluding that the recommendations and guidelines in TR-102323 provide an adequate method for qualifying digital I&C equipment for a plant's electromagnetic environment without the need for plant-specific EMI surveys if the plant-specific electromagnetic environment is confirmed to be similar to that identified in TR-102323. The Tricon PLC system does not meet the guidance of TR-102323.

Triconex performed electromagnetic compatibility (EMC) tests and measurements on the Tricon PLC system test system in accordance with EPRI TR-102323 and Section 6.3.2 of EPRI TR-107330. The details of the tests and measurements are described in the "EMI/RFI Test Procedure," Triconex document number 7286-510, and the "EMI/RFI Test Report," Triconex document number 7286-527. Specifically, Triconex performed the following tests:

- Low-Frequency Conducted Emissions, 30 Hz to 50 kHz (Test Method CE101)
- High-Frequency Conducted Emissions, 50 kHz to 400 MHz (Test Method CE102)
- Radiated Magnetic Field Emissions, 30 Hz to 100 kHz (Test Method RE101)
- Radiated Electric Field Emissions, 10 kHz to 1 GHz (Test Method RE102)
- Low-Frequency Conducted Susceptibility, 30 Hz to 50 kHz (Test Method CS101)
- High-Frequency Conducted Susceptibility, 50 kHz to 400 MHz (Test Method CS114)
- Radiated Magnetic Field Susceptibility, 30 Hz to 100 kHz (Test Method RS101)
- Radiated Electric Field Susceptibility, 10 kHz to 1 GHz (Test Method RS103)
- Conducted Electrical Fast Transient (EFT) Susceptibility (Test Method IEC 801-4)

With the exception of the 230 Vac Model 8312 chassis power supply modules and the third party field power supply, Triconex subjected all of the Tricon PLC system test system components to EMI/RFI testing as required. At present, Triconex does not offer these two components for safety-related use at nuclear power plants. During EMI/RFI testing, the Tricon PLC system test system was mounted in open instrument racks. No additional cabinet or cable shielding was installed, and no additional noise filters or suppression devices were used on the input/output interfaces. At least one point on each I/O module was monitored for proper operation, and the communications modules were exercised through interfaces with external monitoring devices. Operability and prudency testing was performed following EMI/RFI testing to demonstrate acceptable operation.

Triconex Report No. 7286-527 identifies the following operational anomalies that were recorded during the EMI/RFI testing:

- Figure 2-1 in Triconex Report No. 7286-527 showed that the radiated magnetic field susceptibility test (Test Method RS101) was performed at lower test levels than those required in TR-102323. As a result, this test did not meet the guidance of TR-102323.
- The high-frequency conducted susceptibility test (Test Method CS114) was performed at a maximum noise test level of 95 dB microamps rather than the 103 dB as required by TR-102323. As a result, this test did not meet the guidance of TR-102323.
- Compared to the maximum emission allowed by TR-102323, the Tricon PLC system test system showed higher levels of emissions during the low and high-frequency conducted emissions tests (Test Methods CE101 and CE102) and the radiated electric field emissions tests (Test Method RE102). As a result, this test did not meet the guidance of TR-102323.
- Some of the Tricon PLC system test system input, output, and communications modules exhibited susceptibilities during the low and high-frequency conducted susceptibility tests (Test Methods CS101 and CS114), radiated electric field susceptibility tests (Test Method RS103), and EFT susceptibility tests (Test Method IEC 801-4). In addition, there were several instances in which testing on one cable bundle resulted in susceptibility in another unit. As a result, these tests did not meet the guidance of TR-102323.

In most instances where a susceptibility was noted, Triconex performed sufficient threshold testing to identify the noise level at which acceptable equipment operation was achieved. These threshold levels are defined in Triconex Report No. 7286-527.

Given the problems noted above, the staff finds that the Tricon PLC system did not meet the guidance of EPRI TR-102323 for conducted or radiated EMI/RFI emissions or susceptibility. For this reason, before using Tricon PLC system equipment in safety-related systems in a nuclear power plant, licensees must perform sufficient testing and analysis to ensure that the plant-specific EMI/RFI environment is enveloped by the capabilities of the Tricon PLC system, and that the Tricon PLC system will not affect surrounding equipment.

4.1.3.6 Surge Withstand Testing

EPRI TR-102323 lists capabilities of equipment used in safety-related digital systems in nuclear power plants to withstand electrical surges. The NRC staff concludes that the recommendations in TR-102323 provide an adequate method for qualifying digital I&C equipment for a plant's electromagnetic environment without the need for plant-specific EMI surveys provided that the plant-specific electromagnetic environment is confirmed to be similar to that identified in TR-102323.

Triconex tested the ability of the Tricon PLC test system to withstand electrical surges in accordance with EPRI TR-102323 and Section 6.3.5 of EPRI TR-107330. The details of the tests are described in the "Surge Withstand Test Procedure," Triconex document number 7286-508, and the "Surge Test Report," Triconex document number 7286-528. In summary, Triconex performed the following tests:

- IEEE C62.41 Ring Wave Test, 3.0 kV: Chassis Power Supplies
- IEC 801-5 Combination Wave Test, 3.0 kV: Chassis Power Supplies
- IEC 801-5 Combination Wave Test, 0.5 kV and 1.0 kV: Discrete Input Modules
- IEC 801-5 Combination Wave Test, 0.5 kV and 1.0 kV: Discrete Output Modules
- IEC 801-5 Combination Wave Test, 1.0 kV: Analog I/O Modules
- IEC 801-5 Combination Wave Test, 1.0 kV: Communications Modules

Triconex Report No. 7286-528 stated that EPRI TR-102323 requires surge testing to be performed in accordance with IEEE C62.41 using applied surge test voltages of 3,000 V peak. However, IEEE C62.41 does not address surge testing of signal and data communication lines. Therefore, Triconex tested these circuits in accordance with IEC 801-5 at peak voltage levels of 500 V and 1,000 V, as recommended for demonstration of basic immunity of I/O circuits. The staff concludes that the surge withstand test levels applied during testing are adequate to demonstrate this level of surge withstand capability. However, before installing Tricon PLC system equipment in safety-related applications in a nuclear power plant, licensees must ensure that the applied test levels envelope the plant surge environment.

Triconex subjected all of the Tricon PLC test system components to surge withstand testing as required, except for the Model 8312 230-Vac chassis power supply modules and the third-party field power supply. At present, Triconex does not offer these two components for safety-related use in nuclear power plants. During surge withstand testing, the Tricon PLC system was mounted in open instrument racks. No additional surge suppression devices were used on the I/O interfaces. At least one point on each I/O module was monitored for proper operation, and the communications modules were exercised through interfaces with external monitoring devices. Operability and prudency testing was performed following surge withstand testing to demonstrate acceptable operation.

Triconex Report No. 7286-528 concludes that throughout all surge withstand testing, the Tricon PLC test system continued to operate in accordance with the acceptance criteria given in EPRI TR-107330. The report notes that although the test acceptance criteria were met, the following five digital output modules exhibited vulnerability (permanent damage) to the applied surge test levels:

- Model 3611E, 115-Vac digital output;
- Model 3604E, 24-Vdc digital output;
- Model 3624, 24-Vdc digital output;
- Model 3607E, 48-Vdc digital output; and
- Model 3623, 120-Vdc digital output.

Report No. 7286-528 concludes that the above modules are not acceptable for safety-related applications, which are susceptible to surge voltages on the discrete output lines unless qualified surge suppression devices are installed.

The staff accepts the surge withstand test results reported in Triconex Report No. 7286-528 and concludes that the Tricon PLC system is acceptable to the levels to which the equipment was tested. However, the five models listed above are not approved for safety-related use in a nuclear power plant unless licensees can demonstrate by test or analysis that the plant surge withstand requirements for the specific use and in the specific location are enveloped by the demonstrated surge withstand capabilities of the Tricon PLC system. In addition, before installing Tricon PLC system equipment for any use in a nuclear power plant, licensees must ensure that the test levels envelop the plant-specific electrical surge environment.

4.1.3.7 ESD Withstand Testing

EPRI TR-102323 recommends levels of ESD capability for safety-related digital I&C equipment. The staff concludes that those recommendations provide an adequate method for qualifying digital I&C equipment for a plant's electromagnetic environment without the need for plant-specific EMI surveys provided that the plant-specific electromagnetic environment is confirmed to be similar to that identified in TR-102323.

Triconex did not perform ESD withstand testing of the Tricon PLC test system as part of the equipment qualification program. Triconex document number 7286-500, "Nuclear Qualification of Tricon PLC System, Master Test Plan," explains that per TR-102323, test points for ESD testing are selected on the basis of accessibility during operation. Because the Tricon PLC system is intended for installation in a fully surrounding cabinet, all points of accessibility during operation are eliminated. In addition, EPRI TR-1000799 includes requirements for installation and operation of the Tricon PLC system that addresses control of ESD sources.

The staff accepts Triconex's position on ESD withstand capability, with the requirement that the licensees must have in place administrative or physical controls to ensure that no activity that would require opening the cabinet (including maintenance, repair, or calibration) can take place while the Tricon PLC system is required to provide its protective function, unless the particular cabinet and all channels within that cabinet are placed in trip or bypassed condition according to plant procedures. The alternative solution is for licensees to perform sufficient testing and analysis to demonstrate that the ESD withstand capability of the Tricon PLC system envelops the plant-specific ESD withstand requirements. In either case (administrative and physical controls or test and analysis), the staff will review the licensee's ESD provisions.

4.1.3.8 Class 1E to Non-1E Isolation Testing

Triconex performed isolation testing on the Tricon PLC test system in accordance with IEEE Std 384 and Section 6.3.6 of EPRI TR-107330. The details of the tests are described in the "1E/Non-1E Isolation Test Procedure," Triconex document number 7286-509, and in the "1E/Non-1E Isolation Test Report," Triconex document number 7286-529.

Through its testing, Triconex showed that the following Tricon PLC system modules are capable of acting as electrical isolation devices between the designated safety-related hardware of the PLC system and non-safety-related field circuit connections:

- Model 4119AN, EICM Module, RS-232 Serial Port (MODBUS) Interface
- Model 4329N, NCM Module, IEEE 802.3 Interface
- Model 4609N, ACM Module, Dual Nodebus (DNBI) and RS-423 Interfaces
- Model 3636RN, Relay Output Module

The Class 1E to non-1E isolation tests performed on the modules listed above demonstrated isolation capability complying with Section 7.2.2.1 of IEEE 384, including: (1) the isolation device prevents shorts, grounds and open circuits on the non-1E side from unacceptably degrading the operation of the circuits on the 1E side, and (2) the isolation device prevents application of the maximum credible voltage on the non-1E side from unacceptably degrading the operation of the circuits on the 1E side. Triconex also tested the EICM, ACM and NCM modules for a maximum isolation capability of 250 Vac and 250 Vdc applied for 30 seconds, consistent with the maximum credible voltage that could be imposed on the non-1E interfaces if routed separately from high-voltage (>120 Vac) cables. In addition, Triconex tested the Model 3636R module for a maximum isolation capability of 600 Vac and 250 Vdc applied for 30 seconds, consistent with the maximum test levels provided in EPRI TR-107330.

During electrical isolation testing, the Tricon PLC test system was mounted in open instrument racks. No additional electrical protection devices were used on the I/O interfaces. At least one point on each I/O module was monitored for proper operation, and the communications modules were exercised through interfaces with external monitoring devices. Operability and prudence testing was performed following electrical isolation testing to demonstrate acceptable operation.

The Tricon PLC test system used a fiber optic link to connect two of the expansion chassis to the system's main chassis. Triconex has demonstrated by analysis that the fiber optic cables provide electrical isolation between the main chassis and the fiber optically linked expansion chassis. The basis for this conclusion is that since the fiber optic cables do not conduct electricity, they are incapable of transmitting electrical faults. In addition, the operability and prudence testing demonstrated that faults and failures of the fiber optic link do not degrade operation of the main chassis hardware.

The staff determined that the Tricon PLC system design, which separates Class 1E modules from non-1E modules by the fiber optic link, has adequate electrical isolation between Class 1E and non-1E equipment and is suitable in this regard for safety-related use in nuclear power plants. However, the staff finds that before installing the plant-specific Tricon PLC system

equipment, licensees must verify that the maximum test voltages cited above envelop the maximum credible voltages applied to non-1E interfaces.

4.2 Tricon PLC Software Design Review

The bases used by the staff for the review of the Tricon PLC system software include SRP Chapter 7, BTP's 14 and 18, EPRI TR-107330 and TR-106439. Triconex documented the compliance of the Tricon PLC system with these standards in Triconex document number 7286-535, "Nuclear Qualification of Tricon PLC System, Software Qualification Report."

The software qualification consisted of evaluating the processes, procedures, and practices used to develop the software; reviewing the software architecture; and assessing the history of the software and its associated documentation and operating experience. The object of this software qualification was to give the staff reasonable assurance that the quality of the Tricon PLC system is similar to the quality expected of a product developed under a nuclear QA program complying with Appendix B to 10 CFR Part 50.

The staff used the following criteria to determine the acceptability of the software used in the Tricon PLC system:

- SRP Section 7.1, "Instrumentation and Controls - Introduction"
- SRP Appendix 7.0-A, "Review Process for Digital Instrumentation and Control Systems"
- BTP HICB-14, "Guidance on Software Reviews for Digital Computer-Based Instrumentation and Control Systems"
- BTP HICB-18, "Guidance On the Use of Programmable Logic Controllers in Digital Computer-Based Instrumentation and Control Systems"
- NRC Regulatory Guide (RG) 1.152, which endorses IEEE Std 7-4.3.2, "IEEE Standard Criteria for Digital Computers in Safety Systems of Nuclear Power Generation Stations"

Triconex submitted its evaluation of the Tricon PLC system and TriStation 1131 software, including documentation, development practices, and operating history against these criteria. Details of the Triconex evaluation are contained in the "Software Qualification Report," Triconex document number 7286-535. The staff reviewed this evaluation, as well as original design documents and Triconex procedures, as discussed in the following subsections.

4.2.1 Software Documentation

On the basis of NUREG/CR-6241 and ASME NQA-1-1994, Section 8.7 of EPRI TR-107330 lists the documents that are needed as a minimum to support software verification and validation (V&V) and the related software quality processes:

- software quality assurance plan
- software requirements specification
- software design description

- software V&V plan
- software V&V report
- user documentation (manuals)
- software configuration management plan

As with most commercial-grade equipment that is not designed in accordance with Appendix B to 10 CFR Part 50, these documents do not exist as separate entities; rather the required information is contained in various other documents. In the case of the Tricon PLC system, the staff determined that the required software documentation for the Tricon PLC system is contained within the following Triconex documents:

- Triconex quality and engineering procedures, which provide planning requirements for quality assurance, V&V, configuration management, and test activities.
- The original Tricon PLC system functional requirements specifications.
- A series of Tricon PLC system software design specifications that define the incremental changes to the system.
- Test procedures and test reports applicable to each system revision for both hardware and software.
- The Tricon PLC system software release definition documents that identify software changes made in each revision.
- The Tricon PLC system user documentation.

As part of the qualification effort, Triconex reviewed the documentation associated with Version 9.5.3 of the Tricon PLC system software, and documented the review in the Software Qualification Report. The NRC staff reviewed the Software Qualification Report and the associated documentation, and determined that the Triconex QA and engineering procedures were of sufficient quality to provide reasonable assurance that the development process met the provisions for software planning documents as defined in BTP-14. In addition, the NRC staff found that the software development, V&V, and test documentation of the Triconex PLC software was in compliance with both Triconex procedural requirements and the general requirements of current industry standards. The staff further determined that the Tricon PLC system software documentation is acceptable for software intended for safety-related use in nuclear power plants.

4.2.2 Software Development and Life Cycle Planning

One of the guiding principles for approving COTS software for use in nuclear safety-related applications is that there must be reasonable assurance that the equipment will perform its intended safety function and that it is equivalent to an item designed and manufactured under a quality assurance program consistent with Appendix B to 10 CFR Part 50. To accomplish this, the SRP emphasizes the implementation and evaluation of the COTS software development process and life cycle planning. To aid in the evaluation, HICB BTP-14 (Section 2.1) states that

the information to be reviewed for the software development and life cycle planning should include the following documents:

- Software Management Plan
- Software Development Plan
- Software Quality Assurance Plan
- Software Integration Plan
- Software Installation Plan
- Software Maintenance Plan
- Software Training Plan
- Software Operations Plan
- Software Safety Plan
- Software Verification and Validation Plan
- Software Configuration Management Plan

Like most COTS products, the Tricon PLC system was not developed to the provisions of BTP-14, and therefore the information provided in accordance with BTP-14 was not organized into the 11 documents as shown above, but was contained in the following documents showing the development and life cycle planning of the Tricon PLC system software:

- Triconex Quality Assurance Manual
- Triconex Quality Procedures Manual
- Triconex Engineering Department Manual

The QAM provides the overall Triconex corporate QA requirements, while the QPM contains specific procedures for the QA organization (including validation testing), and the EDM defines the specific procedures for development, verification, configuration control, maintenance, and enhancement of the Tricon PLC system product. While the QAM and QPM provide some software specific requirements, the EDM provides the specific procedures that relate to development, maintenance, and life cycle activities of the Tricon PLC system software. In general, Triconex has improved the Tricon PLC system manuals and procedures during the years in which the Tricon PLC system has been produced. The Triconex review of the QAM, QPM and EDM is discussed in the "Software Qualification Report," which shows continual refinement of the life cycle procedures to ensure a quality product and reliable Tricon PLC system.

The staff notes that current processes and procedures contained in the QAM, QPM, and EDM documents have previously been audited by the South Texas Project (STP) Nuclear Operating Company in accordance with the Nuclear Procurement Issues Committee (NUPIC) checklist, and that audit determined that the Triconex program complies with Appendix B to 10 CFR Part 50, as documented in STP Audit Report 97-047(VA). The three year follow-up audit was documented in STP Audit Report 00-067(VA). However, the staff did not review these reports and did not use them as a portion of the basis for approving the Tricon PLC system. On the basis of its review of Triconex documents, the staff finds that the software development and life cycle planning for the Tricon PLC system is adequate for software that is intended for safety-related use in nuclear power plants. The following subsections discuss specific aspects of the software documentation.

4.2.2.1 Software Management Plan

The Tricon PLC software management plan is not contained in a stand-alone document; rather, the QAM, QPM, and EDM provide the basis for overall product management of the Tricon PLC system software. Most of the software management details for the Tricon PLC system product are listed in the EDM. Section 3.1.2.1 of Appendix A to the Software Qualification Report assesses the Tricon PLC system software management plan contained in the QAM, QPM, and EDM against provisions in Section 3.1a of BTP-14. The staff reviewed the software management plan details as discussed in the Software Qualification Report, and concludes that the management structure presented in the related documents provides adequate project oversight, control, reporting, review, and assessment. Furthermore, the NRC staff determined that the QAM, QPM, and EDM documents meet the software management provisions outlined in BTP-14 and are, therefore, acceptable for software intended for safety-related use in nuclear power plants.

4.2.2.2 Software Development Plan

The QAM, QPM, and EDM procedures provide the basis for overall product management of the Tricon PLC system software. Most of the software management details of the Tricon PLC system product are listed in the EDM. The initial 1986 procedures, with some expansion and revision, were used to develop Version 6.2.3 of the Tricon PLC system, the first version to achieve TÜV-Rheinland certification on February 11, 1990. Subsequent versions of the Tricon PLC system software have continued the TÜV-Rheinland oversight and certification, as well as independent verifications. The latest version of the Tricon software, Version 9.5.3, was certified by TÜV on September 17, 2001 in report number 968/EZ 105.02/01.

Section 3.1.2.2 of Appendix A to the Triconex "Software Qualification Report" assesses the Tricon PLC system software development plan contained in the QAM, QPM, and EDM against provisions in Section 3.1b of BTP-14. Having reviewed the software development plan details discussed in the Software Qualification Report, the staff finds the related documents describe acceptable methods of organizing the software life cycle. The staff further finds that the software development plan details contained throughout the QAM, QPM, and EDM conform to the guidance of IEEE Std 1074-1995, "IEEE Standard for Developing Software Life Cycle Processes," endorsed by RG 1.173. The staff therefore concludes that the software development plan identified in the Triconex application is acceptable for software that is intended for safety-related use in nuclear power plants.

4.2.2.3 Software Quality Assurance Plan

The QAM, QPM, and EDM procedures provide the basis for overall quality assurance of the Tricon PLC system software. Most of the software quality assurance details of the Tricon PLC system product are listed in the QAM. Section 3.1.2.3 of Appendix A to the Triconex "Software Qualification Report," assesses the Tricon PLC system software management plan contained in the QAM, QPM, and EDM against provisions in Section 3.1c of BTP-14.

Triconex has had a QA program in place since 1985. The company revised this program in 1997 with the specific intent of making it compliant with the requirements of Appendix B to 10 CFR Part 50. Having reviewed the Triconex software quality assurance plan, the staff

concludes that the Triconex software quality assurance plan is acceptable for software that is intended for safety-related use in nuclear power plants.

4.2.2.4 Software Integration Plan

Having reviewed the Software Integration Plan defined in Section 3.1d of BTP-14, Triconex determined that a software integration plan is not applicable to the Tricon PLC system, since the system uses discrete embedded firmware chips for the various processing boards, such as the main processor and I/O boards. The software modules are small, independent, and run on dedicated microprocessors that do not utilize operating systems, and they require no special software integration activities. Software written for the embedded firmware must be burned onto PROMs that are installed onto processor boards. Having reviewed this discussion in the Triconex Software Qualification Report, the staff agrees that because of the nature of the Tricon PLC system software, no software integration is required or performed and, therefore, the software integration plan outlined in Section 3.1d of BTP-14 is not applicable to this product. No determination of adequacy was required.

4.2.2.5 Software Installation Plan

Having evaluated Section 3.1e of BTP-14, Triconex concluded that the installation characteristics apply to the application programs that would be developed and installed by the users of the Tricon PLC system platform but do not apply to the on-board embedded software. Having reviewed this discussion, the staff agrees that because of the nature of the Tricon PLC system and its firmware (software contained on a PROM), no software installation plan is required. The staff further concluded that the installation plan used by the licensee or other installer of plant-specific software must be evaluated by the staff before the Tricon PLC system software can be used for safety-related use in nuclear power plants.

4.2.2.6 Software Maintenance Plan

The QAM, QPM, and EDM procedures provide the basis for the Tricon PLC software maintenance plan. Most of the software maintenance details for the Tricon PLC system product are listed in the EDM. Section 3.1.2.6 of Appendix A to the Triconex Software Qualification Report assesses the Tricon PLC system software maintenance plan contained in the QAM, QPM, and EDM against provisions in Section 3.1f of BTP-14. The Software Qualification Report also discussed the Triconex review of the QAM, QPM, and EDM documents. The staff reviewed these documents and determined that the QAM, QPM, and EDM contain the necessary management, implementation, and resource characteristics related to software maintenance during the active phase of the product as set forth by BTP-14 and, therefore, are acceptable for software that is intended for safety-related use in nuclear power plants.

4.2.2.7 Software Training Plan

Having evaluated Section 3.1g of BTP-14, Triconex determined that the software training requirements focus on user applications. Triconex provides to its customers a technical training

brochure that describes various courses offered regarding the basic Tricon PLC system unit. These courses include maintenance, user application programming, and advanced technical topics. Having reviewed the software training program offered by Triconex, the staff concludes that the specified end users training plans for the Tricon PLC software meet the criteria outlined in BTP-14 and therefore are acceptable for software that is intended for safety-related use in nuclear power plants. System level training is discussed in Section 4.3.7 of this SE.

4.2.2.8 Software Operations Plan

The software operations plan is a plant-specific requirement of the software user. Licensees are required to have a software operations plan when installing or using the Tricon PLC system in safety-related applications. The staff reviewed the user documentation for the basic platform, described under the heading of Software Life Cycle Process Design Outputs, and found it to be suitable for use and reference when the licensee implements a plant-specific Software Operations Plan.

4.2.2.9 Software Safety Plan

Section 3.1i of BTP-14 characterizes the software safety plans as a requirement of the software user. Licensees are required to have a software safety plan when installing or using the Tricon PLC system in safety-related applications. The guidance for the software safety plan are outlined in the SRP and in IEEE Std 1228, "IEEE Std for Software Safety Plans." The staff reviewed the safety plans related to the Tricon PLC system software as contained in the EDM and discussed in Section 3.1.2.9 of the Triconex "Software Qualification Report," Triconex Report No. 7286-535, and found them to be suitable for use and reference when the licensees implement plant-specific software operations plans.

4.2.2.10 Software Verification and Validation Plan

The NRC's RG 1.168 endorses IEEE Std 1012-1986, "IEEE Standard for Software Verification and Validation Plans," as an acceptable methodology for the verification and validation of safety system software. However, because the Tricon PLC system was originally designed as a commercial product rather than nuclear-grade equipment, not in accordance with Appendix B to 10 CFR Part 50, Triconex did not follow the verification and validation process shown in IEEE Std 1012. Instead, Triconex used a similar (but not identical) process that includes verification and validation. The staff reviewed this process to determine if it is adequate to produce software that is intended for safety-related use in nuclear power plants. The QAM, QPM, and EDM procedures provide the basis for the verification and validation of the Tricon PLC system software, and Triconex provided a detailed assessment of the processes in the Software Qualification Report.

Verification techniques used by Triconex include design document review and code walkthrough to verify the correctness of code modifications and functionality enhancements. Validation activities include functional tests, including regression testing, of the integrated system in accordance with written test procedures. In addition, hardware and software design upgrades and enhancements are tested using the automated fault insertion tests to validate the diagnostic capability and software associated with diagnostics. The TriStation 1131 software is tested by manual and automated tests in accordance with written functional test procedures

that validate correct operation of both the TriStation 1131 and the Tricon PLC system. Functional outputs, boundary conditions, value conversions, and other essential functions are validated in this test.

The Triconex V&V activities were supplemented by two independent reviews of the process and V&V activities, the first performed by TÜV-Rheinland, and the second by MPR and ProDesCon.

TÜV-Rheinland is a German third-party certification agency that verifies and validates equipment to existing international standards. In 1992, TÜV-Rheinland first certified Version 6.2.3 of the Tricon PLC system to meet standard DIN V VDE 19250, "Fundamental Safety Aspects to be Considered for Measurement and Control Protective Equipment," and DIN V VDE 0801, "Principles for Computers in Safety-Related Systems" (Test Report 945/EL 366/91), for level 5 equipment. Each new version has been inspected and tested by TÜV-Rheinland, with Version 9.5.3 being certified on September 17, 2001. The inspection and testing performed by TÜV-Rheinland is on both hardware and software. The system software for the main processors and associated communication and I/O support modules and the TriStation 1131 application development tools software were reviewed and tested with each new version.

The three aspects of software review and testing by TÜV-Rheinland are software analysis, software testing, and integrated system (software/hardware) testing.

The TÜV-Rheinland software analysis consists of examining the code and supporting documentation to ensure that specifications are met and that good practices are used during the development. The software/firmware modules are checked to verify that their functions are as described in the module's specification. From the specification, the source code is examined to ensure that the source code implements the specification. The analysis also evaluates measures taken to avoid common-mode software failures. The emphasis is on examining the software development process and quality controls used by Triconex.

TÜV-Rheinland testing of the TriStation software consisted of checking the translation of the graphical or text user program to the final code. TÜV-Rheinland testing of the Tricon PLC system software consists of the following:

- Internal Fault Routines – Procedures such as the watchdog routines, control processing unit (CPU) test, etc., were checked by either monitoring execution of the routines or by forcing the routines by means of fault insertion. This was done to ensure that faults were properly diagnosed and handled.
- Noise on the Processor – A software module was developed to simulate noise on the processor by putting the CPU address pointer to arbitrary positions and verifying proper detection. This was to simulate what may occur if the address pointer was corrupted by noise on the address lines.
- Functional Verification – Portions of the Triconex functional verification procedures were performed to verify the software module's performance and validity of the test procedure.

Software and integrated system testing is performed to verify external communication and fault detection capabilities.

Since Version 6.2.3, the TÜV-Rheinland certification process has provided a second layer of V&V, this time with the required independence. While the TÜV certification process focuses on obtaining a safety certification, the process requires a set of V&V activities. The staff reviewed the TÜV-Rheinland certification reports and noted that the standards referenced are not nuclear-specific standards, and have not been endorsed by the staff. The standards are, however, appropriate for high-reliability safety-related commercial equipment, and therefore appropriate for the intended usage at that time. The review was thorough, detailed, and adequate to show the high quality of the Tricon PLC system equipment and the supporting TriStation 1131 software tools.

MPR and ProDesCon performed a second independent V&V effort. ProDesCon is an independent V&V contractor, and has been involved in evaluating safety-related software for the nuclear power industry for more than 10 years. In this instance, the review was consistent with the guidance provided in EPRI TR-107330, which states that qualification of software is to be performed using the guidance provided in EPRI TR-106439. This was not a complete line-by-line review of the software, but rather an evaluation of the processes, procedures, and practices used to develop the software; review of the history of the software itself and its associated documentation and operating experience; and analysis of the software architecture. The software included in the V&V effort was the embedded real time operating system with its associated communication and I/O modules and the PC-based system configuration software (TriStation 1131 Developers Workstation, Version 2.0, Service Pack 3).

The purpose of the MPR and ProDesCon review was to determine acceptability of the Tricon PLC system as a platform for implementing nuclear safety-related functions, acceptability of the Triconex development and maintenance processes, and to ensure that future Tricon PLC system releases will continue to have an equivalent level of integrity. For this purpose, the review was divided in two areas:

- Evaluation of the Triconex software development process, on the basis of guidance provided in HICB-BTP14.
- Evaluation of system design and integrity on the basis of guidance provided in IEEE Std 7-4.3.2, "IEEE Standard Criteria for Digital Computers in Safety Systems of Nuclear Power Generation Stations."

The evaluation by MPR and ProDesCon revealed strengths in the Triconex software development process, including the quality of the final product, design partitioning, product testing, error diagnosis and reporting, and change and configuration control. However, the evaluation also identified weaknesses in the maintenance of design basis documentation and in documentation review (or verification) of those documents. Specifically, the review determined that while design verification documentation has become more formal in the current versions of software documentation, the internal verification activities do not provide formal traceability from document to document. The MPR and ProDesCon reviewers determined that the TÜV certification activities provided this traceability, and therefore compensated for the weakness found in the Triconex V&V procedures. The reviewers concluded that "these weaknesses are

adequately compensated for by reviews provided by a classically independent external agency (TÜV-Rheinland) and the quality of the work performed by the Triconex design and validation staff." The evaluation stated that "...taken alone, the internal documentation would not be sufficient to meet the intent of an IEEE1012 in many areas, particularly for versions prior to 6.2.3...", but the evaluation also stated that since the issuance of Version 6.2.3, the TÜV-Rheinland certification process has provided a second layer of classically independent verification and validation. While the TÜV-Rheinland certification process focuses on obtaining a "safety" certification, the process requires a set of V&V activities. Together, the internal Triconex review and the TÜV-Rheinland reviews provides an equivalent level of confidence to that obtained in an IEEE Std 1012 compliant program.

The staff has reviewed the evaluation conducted by MPR and ProDesCon, and although Triconex did not strictly follow IEEE Std 1012 guidelines, the combination of the internal Triconex review, the TÜV certification, and the review by MPR and ProDesCon, gives the staff confidence that the verification and validation activities related to the Tricon PLC system software are adequate. The staff, therefore, concludes that the Tricon PLC system verification and validation activities are acceptable for software that is intended for safety-related use in nuclear power plants. It should be noted, however, that acceptance of the Tricon PLC system is based to a large degree on the TÜV-Rheinland independent review, and any future version of the Tricon PLC system will require an equivalent level of independent V&V in order to be considered acceptable for safety-related use in nuclear power plants.

4.2.2.11 Configuration Management and Error Notification

The QAM, QPM, and EDM provide the basis for overall configuration management of the Tricon PLC system software. Most of the software configuration management details for the Tricon PLC product are listed in the EDM. Section 3.1.2.11 of Appendix A to the Triconex Software Qualification Report comprises the Tricon PLC software configuration management plan contained in the QAM, QPM, and EDM against provisions in Section 3.1k of BTP-14.

Triconex has a formal configuration control, change control, and error tracking system. Software and documents, once placed under configuration control, are retrievable and changes are controlled.

The Tricon PLC system has a number of firmware sets on several modules. A Tricon PLC system version is defined in a formally released, configuration controlled software release definition. These documents define the unique compilation number for each firmware set in a Tricon PLC system and TriStation 1131 release. The firmware defined in each software release definition has been validated by both Triconex Product Assurance and TÜV-Rheinland. The minimum supported hardware, software, and firmware levels are defined in the Product Release Notice.

Versions of the Tricon PLC system are controlled with a numbering system that provides the major, minor, and maintenance version data. Major versions, such as 6.0, 7.0, 8.0, and 9.0, typically involve extensive hardware and/or software changes. As an example, Version 9.0 reflected a change in the system chassis, removing the terminations from plug-in modules with the I/O modules to Elco connectors on the top of the chassis.

The configuration control system includes a customer history tracking system, that lists each Tricon PLC system and module, by serial number, defining where the module is, when it was installed, and any repairs done by Triconex. It is used to monitor product operating experience, to facilitate technical support, and to support customer notification.

Triconex also has an established error tracking and reporting program that is consistent with the requirements established in 10 CFR Part 21. Errors are classified according to severity, with product alert notices (PANs) being the most significant. Six PANs have been issued and all six were evaluated as part of this qualification process. Triconex uses a conservative approach to customer notification, in which all customers are notified of any potential problems, instead of attempting to determine which customers might be at risk. In addition to this safety-critical issue notification system, other notification systems exist to disseminate technical data. Triconex has committed to adopt 10 CFR Part 21 reporting requirements once the Tricon PLC system is in use at nuclear power plants.

Once entered into the automated error tracking system, errors are retrievable, changes are controlled, appropriate resolutions are generated, and all data are available. After review for implementation risk by the change control board, corrections may be held for future implementation, released for immediate resolution, or indefinitely postponed. Customer notification is also addressed in this decision. Immediate customer notification will result if possible safety implications exist.

The staff has reviewed the configuration management plan details discussed in the Software Qualification Report and the error notification processes discussed in the summary report. One of the PANs discussed above occurred during the staff's review of the Triconex product line, and the staff was able to review the PAN and the decision making methodology used by Triconex. The staff found that the PAN process and the configuration management and error notification practices of Triconex comply with the guidance identified in IEEE Std 828 and IEEE Std 1042, which are endorsed by RG 1.169. Furthermore, the NRC staff concludes that the QAM, QPM, and EDM meet the configuration management provisions outlined in BTP-14 and are, therefore, acceptable for software that is intended for safety-related use in nuclear power plants.

4.2.3 Evaluation of TriStation 1131 Programming Software

Application programs for the Tricon PLC system are generated using the TriStation 1131 Developers Workbench, which runs in a Windows NT environment on a standard PC. The TriStation 1131 is a software tool that allows end users to develop application programs, download those applications to the target Tricon PLC system, and determine the health of an attached Tricon PLC system. The TriStation 1131 PC would not normally be connected while the Tricon PLC system is performing safety-critical functions. The TriStation 1131 does not perform any safety-related functions itself, but it is used to generate the software which perform the safety-related functions. For tools that are not safety-critical, BTP-13 states that they "be qualified with a degree of rigor and level of detail appropriate to the safety significance of the software which is to be developed using those tools."

A description of the TriStation 1131 software, and the functions it performs is contained in Section 2.2.3 of this SE.

For the development of the application programs, the TriStation 1131 provides IEC1131-3 compliant programming languages. It also performs a number of automatic checks on the internal coherence of the application programs and the match between I/O variables and their physical correspondences on the I/O modules. The simulation capabilities of the TriStation 1131 allow the programmer to detect errors in specification and coding. Application programs are downloaded to the Tricon PLC system using an IEEE Std 802.3 protocol with CRC check. Use of this protocol and the checksum verification on the whole message provides a level of confidence that corrupt packets will be detected and, therefore, what is downloaded and received by the PLC is actually what was intended to be downloaded.

The provisions for development tools are given in SRP Section 7.1, which states that computer tools used in the design of digital I&C systems shall not introduce faults into the software that are resident on the computer at the time the computer is performing its safety-related function. The Triconex PLC system is designed such that the Tricon PLC system should not be connected to a TriStation PC during safety-related operation.

As was the case for the operating software, there were three levels of review on the TriStation 1131 software. The first was the Triconex in-house review of the software tool, the second was the review and V&V of the software by TÜV-Rheinland, and the third was a review by MPR and ProDesCon. The staff reviewed the data on these three levels, and determined that (similar to the operating software) the three reviews were sufficient to provide a high degree of confidence that the TriStation 1131 software will not introduce faults into the Tricon PLC system and that should this occur, a proper software test of the plant-specific operational programs will reveal those faults. For this reason, the staff finds the TriStation 1131 tools acceptable to produce software that is intended for safety-related use in nuclear power plants. This approval is contingent on proper testing of the operational software, and these test plans, procedures, and results will be reviewed on a plant-specific basis.

4.2.4 Application Programs

The application program implements the desired protection, monitoring, and control functions defined by the design-basis documents for the plant-specific system. Therefore, the application programs are inherently plant-specific, and are not included within the scope of this SE. Section 5.0 of Appendix B to Triconex Document 7286-545, "Applications Guide," provides guidance on the preparation of application programs. In addition, BTP-18, "Guidance on the Use of Programmable Logic Controllers in Digital Computer-Based Instrumentation and Control Systems," provides additional guidance for use during the review of plant-specific applications programs.

4.3 Tricon PLC System Design Review

As the basis for review of the Tricon PLC system design, the staff used SRP Chapter 7 and the guidance in EPRI TR-107330 and EPRI TR-106439. Triconex documented their compliance with these standards in Triconex document number 7286-545, Revision 1, dated September 18, 2000, as well as Amendment 1, Revision 1 to that report.

4.3.1 Failure Modes and Effects Analysis

Triconex performed a failure modes and effects analysis (FMEA) on the Tricon PLC system platform, and documented that analysis in Triconex document number 7286-532. This FMEA was done in accordance with the guidelines of Section 6.4.1 of TR-107330 and the requirements of IEEE 352, Sections 4.1, 4.4, and 4.5. The FMEA reviewed possible failures of the Tricon PLC system components, identified the mechanisms that could cause those failures, and evaluated the consequences of those failures on the operation of the Tricon PLC system. Triconex stated that because of the architecture of the Tricon PLC system, failure mechanisms that affect a single leg of the triple-redundant system generally have no effect on system operation. Therefore, the FMEA also considered (1) failure mechanisms that are recognized as being highly unlikely but could affect multiple components, and (2) the coincident occurrence of otherwise single failures (i.e., multiple failures).

The staff reviewed this FMEA and concurs with the analysis. The results of the FMEA showed that, in general, failure modes that could prevent a Tricon PLC system from performing its safety function are detected by the built-in system diagnostics, or by periodic testing. The staff concluded that the FMEA shows that the Tricon PLC system is suitable for use in safety-related applications in a nuclear power plant. The analysis and results in the Triconex FMEA are also suitable for reference by licensees and for incorporation into plant-specific FMEA analyses.

4.3.2 Reliability and Availability Analysis

The *availability* of a system is the probability that the system will operate on demand, and in particular that it will initiate a protective action when required. The *reliability* of a system is the probability that the system will perform its required function under specified conditions for a specified period of time.

Triconex performed a reliability and availability analysis on the Tricon PLC system in accordance with Section 4.2.3 of EPRI TR-107330 and documented the results in Triconex document number 7286-531. The study determined that the calculated reliability and availability of a typical Tricon PLC system are greater than 99.9 percent, which exceeds the goal of 99.0 percent recommended by EPRI TR-107330. With an assumed periodic test interval of 18 months, typical of nuclear plant refueling outage cycles, the reliability and availability increase to greater than 99.98 percent. The staff reviewed this study, and agrees that the results of the reliability and availability analysis support use of the Tricon PLC system in safety-related applications in a nuclear power plant, and the analysis and its results are appropriate for incorporation in plant-specific risk analyses.

4.3.3 Component Aging Analysis

Triconex performed a component aging analysis on the Tricon PLC system in accordance with Section 4.7.8.2 of EPRI TR-107330. The analysis is contained in Section 4.12 of the Triconex Qualification Summary Report, document number 7286-545, with additional details provided in the August 30, 2001, letter from Triconex (Accession Number ML012490183). The intent of the analysis was to identify significant aging mechanisms; establish a qualified life for the hardware on the basis of the significant aging mechanisms; and/or specify surveillance, maintenance, and replacement activities to address significant aging-related degradation.

The component aging analysis concluded that the components of the Tricon PLC system that are susceptible to significant, undetected aging mechanisms include only the chassis power supplies and backup batteries. Aging-related degradation of these components can be effectively addressed through periodic replacement before the onset of significant loss of performance. Section 6.3, "Maintenance Procedures," of Appendix B, "Applications Guide," to Triconex Topical Report 7286-545, "Qualification Summary Report," recommends replacement of the backup batteries every 5 years, or when the battery life alarm occurs, and replacement of the power supplies every 10 years.

The staff agrees with the results of the component aging analysis. Before installing Tricon PLC system equipment in a nuclear power plant, licensees must ensure that procedures are in place to ensure periodic replacement of the components identified above at the manufacturer's recommended frequencies given in the Application Guide (Appendix B to the Triconex Qualification Summary Report).

4.3.4 Thread Audit

The staff conducted a "thread audit" walkthrough of the Tricon PLC system hardware and software. Since this review is of a topical report, and not of a plant-specific application, no specific user software was available upon which to base this thread audit. For this reason, during the plant visit at the Triconex site, the staff had Triconex assume a system with analog and digital inputs and a digital output. Triconex demonstrated the method and logic that would be used to select the appropriate modules, and how the application-specific software would be designed. The staff and Triconex design engineers then traced the signal path from the input, through the input modules, to the I/O processor via the I/O bus, to the main processor and the application-specific software; showed how a trip signal would be generated; and assessed how that trip signal would be processed out through the I/O processor, I/O bus, and output modules. This thread audit consisted of the following steps:

- (1) Trace the signal through the hardware components, and verify any transformations (such as analog to digital conversion).
- (2) Review the actual code within the various processors through which the signal passes.
- (3) Examine the various levels of software development documents (such as the software specification and the V&V report), and compare them to the actual code.
- (4) Review the final results of the hardware and software development processes.

During this audit, Triconex personnel were able to quickly retrieve the appropriate documentation; explain the specification, design, review, test, and V&V processes; and walk the staff through the signal and software flow. On the basis of the "thread audit" and the review of the Triconex V&V program, the staff finds that the process is suitable for development of high-quality software suitable for use in safety-related applications in nuclear power plants.

4.3.5 Response Time Characteristics

GDC 20, 21, 23, and 25 (defined in Appendix A to 10 CFR 50) constitute requirements for timely operation of the protection features. To meet these requirements, BTP-21 provides the following guidance:

- The feasibility of design timing may be demonstrated by allocating a timing budget to components of the system architecture (Annex E of IEEE Std 7-4.3.2) so that the entire system meets its timing requirements.
- Timing requirements should be satisfied by design commitments.

Section 4.2.1-A of EPRI TR-107330, "General Functional Requirements," Part A, "Response Time," states, "The overall response time from an input to the PLC exceeding its trip condition to the resulting outputs being set shall be 100 milliseconds or less." Section 5.3, "Operability Test Requirements," Part B, "Response Time" states, "The response time of the loop shall be measured per the requirements of Section 4.2.1, Item A. The response time between receiving a discrete input and setting a discrete output and from changing an analog input to changing an analog output and a discrete output shall be measured in a fashion that is expected to provide repeatable results. The acceptance criteria is that the measured response time shall not vary more than $\pm 20\%$ from the value calculated from the manufacturer's data for the baseline testing and the value measured following qualification testing shall not vary more than $\pm 10\%$ from the baseline. The baseline response time testing shall be performed for any variations in arrangements that result from requirements in Section 6.2.1.1."

MPR Associates performed an analysis of the test system as described in Section 2.3 of this SE, and determined that the theoretical maximum response time for that system was 177 ms for a digital input to digital output signal, and 264 ms for an analog input to digital output signal. This analysis is documented in MPR Calculation No. 426-001/SCS-01, "Test Tricon Maximum Response Time Test Calculation." Triconex performed actual baseline response time tests on the test system, and documented those tests in Triconex documents 7286-503, "Operability Test Procedure," and 7286-530, "Performance Proof Test Report." These tests did not show compliance with the guidance in EPRI TR-107330, but did validate the MPR analysis. Specifically, the test report showed that the test system exhibited digital input to digital output response time values of 144 to 162 ms, and analog input to digital output response time values of 199 to 216 ms.

On the basis of those values, the Tricon PLC system is not in compliance with Section 4.2.1-A of EPRI TR-107330. The actual response time for any particular system will depend upon the actual system configuration, and may vary significantly from simple to complex systems. The determination of the suitability of the Tricon PLC system response time characteristics for a particular plant application is a plant-specific requirement and, therefore is the responsibility of licensees and will be reviewed by the staff during the review of plant-specific applications to ensure that the Tricon PLC system satisfies its plant- and application-specific requirements for system response time presented in the accident analysis in Chapter 15 of the safety analysis report.

4.3.6 Tricon PLC System Self-Diagnostic Capacity

Digital computer-based I&C systems are prone to different kinds of failures than traditional analog systems. Properly designed self-test, diagnostic, and watchdog timers reduce the time to detect and identify failures, but do not guarantee hardware or software error detection. Computer self-testing is most effective at detecting random hardware failures. BTP-17 describes provisions for self-test capabilities for digital systems. The Tricon PLC system provides continuous self-testing, including monitoring memory and memory reference integrity, using watchdog timers, monitoring communication channels, monitoring central processing unit status, and checking data integrity. The Tricon PLC system performs self-tests and I/O validation on each module. The Tricon PLC system TMR architecture provides continuous self-testing to detect, tolerate, and alarm on single internal failures. The internal self-test functions are transparent to the application program and are an integral part of the base platform software. These diagnostics check each main processor, as well as each I/O module and communication channel. Transient faults are recorded and masked by the hardware majority-voting circuit. Persistent faults are diagnosed, and the faulted module can be replaced or operated in a fault-tolerant manner until replacement is completed. The main processor diagnostics do the following:

- Verify fixed-program memory;
- Verify the static portion of RAM;
- Test all basic processor instructions and operating modes;
- Test all basic floating-point processor instructions;
- Verify the shared memory interface with each I/O communication processor and communication leg;
- Verify handshake signals and interrupt signals between the CPU, each I/O communication processor, and communication leg;
- Check each I/O communication processor and communication leg microprocessor, ROM, shared memory access, and loopback of RS-485 transceivers;
- Verify the Triclock interface; and
- Verify the Tribus interface

Each I/O module also has ongoing diagnostics for each leg. Failure of any diagnostic on any leg activates the module's fault indicator, which in turn activates the chassis alarm signal. The fault indicator points to a leg fault, not a module failure. The module will continue to operate properly in the presence of a single fault.

The digital input modules with self-test continuously verify the ability of the Tricon PLC system to detect the transition of a normally energized circuit to the off state. High-density digital input

modules continuously verify the ability of the Tricon PLC system to detect transitions to the opposite state.

The digital output module executes a particular type of output voter diagnostic (OVD) for every point. In general, during OVD execution, the commanded state of each point is momentarily reversed on one of the output drivers, one after another. Loop-back sensing on the module allows each microprocessor to read the output value for the point to determine whether a latent fault exists within the output circuit.

Supervised digital output modules provide both voltage and current loopback, allowing fault coverage for both energized-to-trip and deenergized-to-trip conditions. In addition, a supervised digital output module verifies the presence of the field load by doing continuous circuit-continuity checks. Any loss of field load is annunciated by the power module.

A dc voltage digital output module is specifically designed to control devices that hold points in one state for long periods of time. The OVD strategy for a dc voltage digital output module ensures fault coverage even if the commanded state of the points never changes. On this type of module, an output signal transition occurs during OVD execution, but is guaranteed to be less than 2.0 ms (500 μ s is typical) and is transparent to most field devices.

The Triconex Planning and Installation Guide, a commercial Triconex manual with a Triconex part number of 9720051-006, provides detailed descriptions of each diagnostic test and flag.

The staff reviewed these self-test capabilities, and finds them to be suitable for a digital system used in safety-related applications in nuclear power plants. It may also be possible to use some of these diagnostic capabilities to modify or eliminate certain TS-required periodic surveillance tests; however this is a plant-specific, application-dependent issue and, therefore, is not addressed in this SE. Any such surveillance test modifications or eliminations will be reviewed in plant-specific reviews.

4.3.7 Training

Triconex Quality Assurance Manual, Section QAM 1.2, "Triconex Organization," Revision 009, dated April 23, 1999, contains the description of the functional organization of the corporation, and their authorities and responsibilities. The Customer Satisfaction Department within the organization is responsible for technical support, customer service, worldwide service, and worldwide training. Additionally, the document also identifies training as the responsibility of Human Resources, Customer Satisfaction, and every department per the requirements of QAM 18.0, "Training," Rev. 012, dated January 5, 2001. Specifically, QAM 18.0 describes the procedures that apply to all personnel performing activities that affect the quality of Triconex products. It also identifies positions and processes that require the assignment of certified personnel, the company's training policy, training needs, and the requirements for training records. QAM 18.0 also identifies the training that is provided to Triconex customers for operation and maintenance of the Tricon PLC system. Within Triconex, the Human Resource Department is responsible for managing the overall employee training program, while each department supervisor is responsible for ensuring that his or her employees are appropriately trained and qualified to perform their assigned functions.

The services and warranty programs that Triconex generally provides to its customers include technical product support; system troubleshooting; diagnostic evaluations; onsite support; and software/firmware/hardware upgrades. The procedures for customer service activities are defined in QAM 19.0, Rev. 6, dated April 14, 2000. The Customer Service Department in Irvine, California, is the only location authorized to perform repair work on any Triconex TMR product. QAM 19.0 also requires that all repair activities by Triconex customer servicing groups will meet the same workmanship standards that applied to the manufacturing process for the original product.

The customer is generally responsible for operating and maintaining the Triconex product at a given plant. The Customer Satisfaction Department offers Triconex customers training courses on the operation and maintenance of Triconex products.

The Triconex Training Manual, Document No.5600-0020/99, 1999, describes the training offered by the Triconex Customer Satisfaction Department for all Triconex products. Training is offered at training centers at Houston, Texas, and Irvine, California, in the United States, and at training centers in Europe, the Middle East, and Singapore. Triconex also offers onsite training at customer sites tailored to fit project specific requirements.

The Triconex Training Manual also describes the Tricon/TriStation 1131 Maintenance Course. The course summary is as follows:

This 3-day hands-on course provides an introduction to Tricon PLC system implementation, with its primary focus on maintenance and troubleshooting of the Tricon PLC system. Students get practical experience with continuity checks, loop testing, and general field maintenance. Using TriStation 1131 (Windows NT) software, students monitor Tricon PLC system operations, perform diagnostic procedures, and force points in a real-time environment designed to simulate actual field conditions.

The course is meant for plant supervisors who are responsible for the Tricon PLC system, and plant technicians responsible for installing and maintaining the Tricon PLC system. The course outline includes an introduction to the Tricon PLC system; principles of Tricon PLC system design; Tricon PLC system components; and installing, operating, and maintaining the Tricon PLC system.

Given the review of the information provided and discussions with Triconex personnel, the staff finds that the training provided to Triconex personnel responsible for Tricon products is adequate to ensure that the quality of the products, services offered and overall work performed is acceptable for safety-related applications. For its customers, Triconex has a well-established training program at facilities that are accessible to customers worldwide for operating and maintaining Tricon products installed at customer sites. The training and customer services offered to Triconex customers is comprehensive and adequate for maintaining the quality of the products operating at the customers' plants.

4.3.8 Repair of Tricon PLC System Modules

The Tricon PLC system modules are generally not considered to be field repairable. It is expected that plant repair activities will be limited to replacing of modules, and all faulted or broken modules will be returned to Triconex for repair. Triconex has stated that its policy is that the Customer Service Department in Irvine, California, is the only location authorized to perform repairs on any Triconex TMR product.

4.3.9 Historic Data on Tricon PLC System Use

The staff reviewed the historic data available on the use of the Tricon PLC system in commercial and foreign nuclear applications. Triconex has an ongoing relationship with each customer and, therefore, maintains knowledge about the system configuration and any customer concerns regarding those systems. The operating experience with these systems indicates that the hardware and software is highly reliable. There are more than 2,000 systems in operation, with greater than 100 million operating hours. During this time, there have been no failures to perform the required protective action.

The staff believes that historic data is insufficient by itself to approve any system for safety-related use in nuclear power plants; however, this data does show a degree of quality in the Tricon PLC system design and the advantages of a triple-redundant system. This data also shows that while common-mode software failure of all three portions of a triple redundant system is possible (and may in fact still happen at some location), the quality of the Triconex software design, testing, and applications is such that this type of failure is highly unlikely. This staff observation does not, in any way, reduce or eliminate the need and regulatory requirement for diversity or defense-in-depth.

4.3.10 Defense-in-Depth and Diversity

The staff described concerns with common-mode failures and other digital system design issues in SECY-91-292. Common-mode failures could defeat the redundancy achieved by the hardware architectural structure, and also result in the loss of several echelons of defense in depth (provided by the monitoring, control, reactor protection, and engineered safety functions performed by the digital I&C systems).

The staff has established acceptance guidelines for Defense-in-Depth and Diversity (D-in-D&D) assessments and has identified four echelons of defense against common-mode failures:

- Control system – The control system echelon consists of non-safety equipment which routinely prevents reactor excursions toward unsafe operation, and is used for normal operation of the reactor.
- Reactor trip system (RTS) – The reactor trip echelon consists of safety equipment designed to reduce reactivity rapidly in response to an uncontrolled excursion.
- Engineered safety feature actuation system (ESFAS) – The ESFAS echelon consists of safety equipment which removes heat or otherwise assists in maintaining the integrity of the three physical barriers (cladding, vessel, and containment) to radioactive release.

- Monitoring and indication – The monitoring and indication echelon consists of sensors, displays, data communication systems, and manual controls required for operators to respond to reactor events.

As a result of the reviews of advanced light-water reactor (ALWR) design certification applications that used digital protection systems, the staff documented its position in SECY 93-087, "Policy, Technical, and Licensing Issues Pertaining to Evolutionary and Advanced Light-Water Reactor Design," with respect to common-mode failure in digital systems and defense-in-depth for the advanced reactors. This position is also documented in the SRP BTP HICB-19, "Guidance for Evaluation of Defense-in-Depth and Diversity in Digital Computer Based Instrumentation and Control Systems." There are four points in the position as applied to ALWR design certification applications. These four positions are quoted below.

1. The applicant/licensee should assess the diversity and defense-in-depth of the proposed instrumentation and control system to demonstrate that vulnerabilities to common-mode failures have been adequately addressed.
2. In performing the assessment, the vendor or applicant/licensee shall analyze each postulated common-mode failure for each event that is evaluated in the accident analysis section of the safety analysis report (SAR) using best-estimate methods. The vendor or applicant/licensee shall demonstrate adequate diversity within the design for each of those events.
3. If a postulated common-mode failure could disable a safety function, then a diverse means, with a documented basis that the diverse means is unlikely to be subject to the same common-mode failure, should be required to perform either the same function or a different function. The diverse or different function may be performed by a non-safety system if the system is of sufficient quality to perform the necessary function under the associated event conditions.
4. A set of displays and controls located in the main control room should be provided for manual system-level actuation of critical safety functions and monitoring of parameters that support the safety functions. The displays and controls should be independent and diverse from the safety computer systems identified in items 1 and 3 above.

The staff stated in BTP HICB-19 that Points 1, 2, and 3 of this position apply to digital system modifications for U.S. operating plants. Point 4 of this position applies only to ALWR and new reactor system design certification applications.

Since both diversity and defense-in-depth are plant specific topics, the Triconex Topical Report 7286-545, "Qualification Summary Report," did not address these topics, and they are therefore not within the scope of this SE. Sections 3.6.2 and 3.6.3 of Appendix B, "Applications Guide," to Triconex document number 7286-545, provides guidance in the preparation of a plant specific D-in-D&D evaluation. A review of the differences between the Tricon PLC system and

the non-safety control system implemented at a particular nuclear power plant, and the determination that plant specific required diversity and defense-in-depth continue to be maintained must be addressed in a plant-specific D-in-D&D evaluation. These determinations will be reviewed by the staff during the plant-specific safety evaluation.

5.0 CONCLUSION

The subsections below will discuss the degree of regulatory compliance met by the Tricon PLC system, as well as any licensee actions required before the system can be used for safety-related applications in nuclear power plants.

5.1 Regulatory Compliance

This safety evaluation discusses the acceptability of the Tricon PLC system. The GDC listed in Appendix A to 10 CFR Part 50 establish the minimum requirements for the design of nuclear power plants; 10 CFR 50.55a(h) incorporates IEEE Std 603-1991. The regulatory guides and endorsed industry codes and standards listed in the SRP, Table 7-1, are the guidelines used as the basis for this evaluation.

Section 50.55a(a)(1), "Quality Standards for Systems Important to Safety," is addressed by conformance with the codes and standards listed in the SRP. In the development of the Tricon PLC system, Triconex used codes and standards that are the same as or equivalent to the standards identified in the SRP. Therefore, the staff concludes that the Tricon PLC system conforms with this requirement.

Section 50.55a(h) endorses IEEE Std 603-1991, which addresses both system-level design issues and quality criteria for qualifying devices. Not every section of IEEE Std 603-1991 applies to a topical report with no plant-specific application. The staff has reviewed the requirements of IEEE Std 603-1991, and finds that the following sections apply:

- Section 5.1 requires that a single failure will not prevent proper operation of the protective action. To meet this criterion, a Tricon PLC system is used in each of multiple redundant process channels and trip logic trains for each function. These redundant channels and trains will be electrically isolated and physically separated. This requirement has been satisfied for single hardware failures.
- Sections 5.2 and 7.3 require that once a safety-related protective system action has been initiated, the actuations proceed to completion. Once initiated, the Tricon PLC system will proceed to completion. Return to normal operation requires deliberate operator action.
- Section 5.3 contains the requirement for high-quality systems. This requirement is satisfied by the Triconex Quality Assurance Program.
- Section 5.4 contains the equipment qualification requirements. The topical report describes the degree to which the Tricon PLC system hardware is environmentally and seismically qualified to ensure that the system is capable of performing its designated

functions while exposed to normal, abnormal, test, accident, and post-accident environmental conditions.

- Section 5.6 contains the requirements for physical, electrical, and communications independence. These criteria are met through redundancy and separation of the channels. Communication between channels is via a peer-to-peer communication protocol implemented using Tricon PLC system communications modules that have been demonstrated to be qualified isolation devices.
- Section 5.7 contains testing and calibration requirements. The testing and calibration capabilities of the Tricon PLC system have been demonstrated to be in compliance with RG 1.22, RG 1.118, and IEEE-338. The capability exists to permit testing of redundant channels during power operation. The design does not require disconnecting wires, installing jumpers, or otherwise modifying the installed equipment.
- Section 5.9 requires control of access to the system. Access to the hardware can be controlled via front and rear cabinet doors, which could normally be locked. Also, door positions can be monitored with an alarm to the operator if any door is opened.
- Section 5.15 discusses reliability. Availability and reliability of the Tricon PLC system have been assessed with probabilistic availability and reliability analyses using actual operating experience data. The probabilistic analysis has been used to quantify non-availability on demand. The staff has reviewed these calculations; however, the staff does not use probabilistic and deterministic reliability analyses as the sole means of determining the acceptability of a safety system. The calculations relate only to the hardware aspects of the Tricon PLC system. Despite the staff's determination that the software is of sufficiently high quality to be suitable for use in safety-related systems in nuclear power plants, there is no method to make a verifiable determination of the numeric value of software reliability.
- Sections 6.1 and 7.1 discuss the requirements for automatic control and Sections 6.2 and 7.2 discuss the requirements for manual control. The Tricon PLC system meets these automatic and manual control requirements. In a properly installed system, failure of the automatic controls would not interfere with separately provided manual controls.
- Section 6.8 discusses the determination of setpoints. Triconex has performed an analysis of accuracy, repeatability, thermal effects and other necessary data for use in a plant-specific setpoint analysis. Licensees must ensure that, when the Tricon PLC system is installed, setpoint calculations be reviewed and, if required, setpoints be modified to ensure that the Tricon PLC system equipment will perform within system specifications.

Therefore, the staff has determined that the Tricon PLC system satisfies the requirements of 10 CFR 50.55a(h) with regard to IEEE Std 603-1991.

The staff determined that the following GDCs specified in Appendix A to 10 CFR Part 50 are the applicable design criteria for this review:

- GDC 1: Quality Standards and Records
- GDC 2: Design Basis for Protection Against Natural Phenomena
- GDC 4: Environmental and Missile Design Bases
- GDC 13: Instrumentation and Control
- GDC 20: Protection System Functions
- GDC 21: Protection System Reliability and Test ability
- GDC 22: Protection System Independence
- GDC 23: Protection System Failure Modes
- GDC 24: Separation of Protection and Control Systems
- GDC 29: Protection Against Anticipated Operational Occurrences

The staff reviewed the equipment descriptions in the topical report for conformance to the guidelines in the regulatory guides and industry codes and standards that apply to this equipment. The staff concludes that Triconex adequately identified the guidelines that apply to this equipment. Given the review of the equipment designs for conformance to the guidelines, the staff finds that there is reasonable assurance that the Tricon PLC system conforms to the applicable guidelines. Therefore, the staff finds that the requirements of GDC 1 and 10 CFR 50.55a(a)(1) have been met.

The review included identifying those components and assemblies of the Tricon PLC system that are designed to survive the effects of earthquakes and abnormal environments. On the basis of this review, the staff concludes that Triconex has identified those components and assemblies consistent with the design bases for the intended safety-related applications of the Tricon PLC system. Therefore, the staff finds that the identification of those components and assemblies satisfies the requirements of GDC 2 and 4.

On the bases of its review of the Tricon PLC system status information, manual interface capabilities, and provisions to support safe shutdown, the staff concludes that information is provided to monitor the Tricon PLC system over the anticipated ranges for normal operation, for anticipated operational occurrences, and for accident conditions so as to ensure adequate safety. Appropriate controls can be provided for manual initiation of a reactor trip. The Tricon PLC system can appropriately support actions to safely operate a nuclear power unit under normal conditions and to maintain it in a safe condition under accident conditions. Therefore, the staff finds that the Tricon PLC system design satisfies the requirements of GDC 13.

Given its review of the topical report, the staff concludes that the Tricon PLC system conforms to the design-basis requirements of 10 CFR 50.34(f), and to the guidance of IEEE Std 603 and RG 1.105. The staff also concludes that the Tricon PLC system includes the necessary provisions to detect accident conditions and anticipated operational occurrences in order to initiate reactor shutdown consistent with the accident analysis presented in Chapter 15 of a licensee's SAR. Licensee evaluation of plant-specific accident analyses is required. Therefore, the staff finds that the Tricon PLC system satisfies the requirements of GDC 20.

The Tricon PLC system conforms to the guidelines for periodic testing in RG 1.22 and RG 1.118. Bypassed and inoperable status indication can be supported to conform to the guidelines of RG 1.47. A Tricon PLC system installation can also conform to the guidelines regarding the application of the single-failure criterion in IEEE Std 379, as supplemented by RG 1.53. On the basis of this review, the staff concludes that the Tricon PLC system satisfies the

guidance of IEEE Std 603 with regard to system reliability and testability. Therefore, the staff finds that the Tricon PLC system satisfies the requirements of GDC 21.

On the basis of its review, the staff concludes that the Tricon PLC system satisfies the guidance of IEEE Std 603 and the guidance in RG 1.75 with regard to protection system independence. Therefore, the staff finds that the Tricon PLC system satisfies the requirements of GDC 22.

On the basis of its review of the FMEA for the Tricon PLC system, the staff concludes that the system is designed to fail into a safe mode if conditions such as disconnection of the system, loss of energy, or adverse environment are experienced. Therefore, the staff finds that the Tricon PLC system satisfies the requirements of GDC 23.

Based on its review of the interfaces between the Tricon PLC system and plant operating control systems, the staff concludes that the Tricon PLC system satisfies the guidance of IEEE Std 603 with regard to control and protection system interactions. Therefore, the staff finds that the Tricon PLC system satisfies the requirements of GDC 24.

On the basis of its review of all GDCs listed above, the staff concludes that the Tricon PLC system satisfies the requirements of GDC 29, "Protection Against Anticipated Operational Occurrences."

On the basis of its review of software development plans and inspections of the computer development process and design outputs, the staff concludes that the Tricon PLC system meets the guidance of RG 1.152. Therefore, the special characteristics of computer systems have been adequately addressed, and the staff finds that the Tricon PLC system satisfies the requirements of GDC 1 and 21.

The staff determined that the Tricon PLC system meets the relevant requirements of GDCs 1, 2, 4, 13, 20-24, and 29.

5.2 Plant-Specific Requirements

Section 4.1.3.2 of this SE discusses the temperature and humidity conditions for which the Tricon PLC system is qualified. Licensees will be responsible for analysis of the plant-specific environment, and the determination that the Tricon PLC system is suitable for that particular plant usage. This determination will be reviewed by the staff during the plant-specific safety evaluation.

Section 4.1.3.3 of this SE discusses the radiation exposure levels for which the Tricon PLC system is qualified. Licensees will be responsible for analysis of the plant-specific radiation environment, and the determination that the Tricon PLC system is suitable for that particular plant usage. This determination will be reviewed by the staff during the plant-specific safety evaluation.

Section 4.1.3.4 of this SE discusses the seismic levels for which the Tricon PLC system is qualified. The staff found that the Tricon PLC system did not fully meet the guidance of EPRI TR-107330 for seismic requirements, and before using Tricon PLC system equipment in safety-related systems in a nuclear power plant, licensees must determine that the

plant-specific seismic requirements are enveloped by the capabilities of the Tricon PLC system. This determination, and the suitability of the Tricon PLC system for a particular plant and application is the responsibility of the licensee. This determination will be reviewed by the staff during the plant-specific safety evaluation.

Section 4.1.3.5 of this SE discusses the conducted or radiated EMI/RFI emissions or susceptibility for which the Tricon PLC system is qualified. Since the Tricon PLC system did not satisfy the guidance of EPRI TR-102323, it is the responsibility of the licensees to measure or otherwise determine the worst case EMI/RFI environment that would exist at the time the protective function provided by the Tricon PLC system would be required, and then to ensure that the conducted and radiated EMI/RFI emissions and susceptibility capabilities of the Tricon PLC system envelop this environment, and that the system will not affect surrounding equipment. This determination will be reviewed by the staff during the plant-specific safety evaluation.

Section 4.1.3.6 of this SE discusses the surge withstand capabilities for which the Tricon PLC system is qualified. Licensees will be responsible for the analysis of the plant-specific surge environment, and the determination that the Tricon PLC system is suitable for that particular plant usage. This determination will be reviewed by the staff during the plant-specific safety evaluation.

Section 4.1.3.7 of this SE discusses the ESD withstand capability, and the fact that the Tricon PLC system was not tested for this capability. Before installing and using the Tricon PLC system, licensees must have in place administrative or physical controls to ensure that no activity which would require opening the cabinet can take place while the Tricon PLC system is required to provide its protective function, unless the particular cabinet and all channels within that cabinet are placed in a trip or bypassed condition according to plant procedures. An alternative solution is for licensees to perform sufficient testing and analysis to demonstrate that the ESD withstand capability of the Tricon PLC system envelops the plant-specific requirements. In either case, whether administrative and physical controls or test and analysis, the staff will review the licensees' ESD provisions during the plant-specific safety evaluation.

Section 4.1.3.8 of this SE discusses the Class 1E to non-1E isolation capabilities for which the Tricon PLC system is qualified. Licensees will be responsible for analysis of the plant-specific maximum credible applied voltages produced by non-1E interfaces, and for ensuring that this value is enveloped by the Tricon PLC system capacity, and that the Tricon PLC system is suitable for that particular plant usage. This determination will be reviewed by the staff during the plant-specific safety evaluation.

Section 4.2.2.5 of this SE discusses the software installation plan. The staff determined that the software installation plan is the responsibility of the licensee, and must be developed before the Tricon PLC system software can be used for safety-related applications in nuclear power plants. This software installation plan will be reviewed by the staff during the plant-specific safety evaluation.

Section 4.2.2.6 of this SE discusses the software maintenance plan. Although Triconex has an acceptable software maintenance plan, the staff determined that a plant-specific software maintenance plan is also required, and it is the responsibility of licensees to develop this

software maintenance plan before the Tricon PLC system software can be used for safety-related applications in nuclear power plants. This software maintenance plan will be reviewed by the staff during the plant-specific safety evaluation.

Section 4.2.2.8 of this SE discusses the software operations plan. The staff determined that licensees will be required to develop a software operations plan before using the Tricon PLC system software for safety-related use in nuclear power plants. This software operations plan will be reviewed by the staff during the plant-specific safety evaluation.

Section 4.2.2.9 of this SE discusses the software safety plan. The staff determined that licensees will be required to develop a software safety plan before using the Tricon PLC system software for safety-related applications in nuclear power plants. This software operations plan will be reviewed by the staff during the plant-specific safety evaluation.

Section 4.2.2.10 of this SE discusses verification and validation. Although Triconex did not strictly follow guidelines of IEEE Std 1012, the staff determined that the combination of the internal Triconex review, the TÜV certification, and the review by MPR and ProDesCon provided acceptable verification and validation for software that is intended for safety-related use in nuclear power plants. However, the staff noted that a significant portion of its acceptance is predicated upon the independent review by TÜV-Rheinland, and licensees using any Tricon PLC system beyond Version 9.5.3 must ensure that similar or equivalent independent V&V is performed; without this, the Tricon PLC system will not be considered acceptable for safety-related use at nuclear power plants. Should licensees use future Tricon PLC systems beyond Version 9.5.3 which have not received TÜV-Rheinland certification, the staff will review the acceptability of the independent V&V during the plant-specific safety evaluation.

Section 4.2.3 of this SE discusses the use of the TriStation 1131. That section noted that the Triconex PLC system is designed such that the Tricon PLC system should not be connected to a TriStation PC during safety-related operation. The plant-specific procedures which ensure that the TriStation PC is not connected to the Tricon PLC system during safety-related operation will be reviewed by the staff during the plant-specific safety evaluation. In addition, the testing of the operational software produced by the TriStation 1131, and these test plans, procedures, and results will be reviewed by the staff during the plant-specific safety evaluation.

Section 4.2.4 of this SE discusses the application programs, which are inherently plant specific, and therefore are not included in the scope of this SE. Plant-specific application programs will be reviewed by the staff during the plant-specific safety evaluation.

Section 4.3.3 of this SE discusses the component aging analysis, which determined that the chassis power supplies and backup batteries are susceptible to significant, undetected aging mechanisms. Before installing Tricon PLC system equipment in a nuclear power plant, licensees must have procedures in place to ensure periodic replacement of these components. These procedures will be reviewed by the staff during the plant-specific safety evaluation.

Section 4.3.5 of this SE discusses the response time characteristics of the Tricon PLC system software safety plan. The staff determined that the actual response time for any particular system will depend upon the actual system configuration, and may vary significantly from

simple to complex systems. The determination of the response time for the particular system intended for safety-related use for a particular plant application, and the determination that this response time satisfies the plant-specific requirements in the accident analysis in Chapter 15 of the safety analysis report is the responsibility of the licensee. These determinations will be reviewed by the staff during the plant-specific safety evaluation.

Section 4.3.10 of this SE discusses diversity and defense-in-depth. A review of the differences between the Tricon PLC system and the non-safety control system implemented at a particular nuclear power plant, and the determination that plant specific required diversity and defense-in-depth continue to be maintained must be addressed in a plant-specific D-in-D&D evaluation. These determinations will be reviewed by the staff during the plant-specific safety evaluation.

Triconex has made a number of determinations of items and criteria to be considered when applying the Tricon PLC system to a specific plant application. These are contained in the "Applications Guide," provided as Appendix B to the "Qualification Summary Report," Triconex document number 7286-545. A number of these are the same as those discussed above, but the "Applications Guide" goes beyond regulatory compliance to include good engineering practice and applications suitability determinations. It is expected that licensees intending to use the Tricon PLC system will consider each item in this guide, and document the appropriate decisions and required analysis. The staff will review these decisions and analysis during the plant-specific safety evaluation.

5.3 Approval

The staff concludes that the Tricon PLC system meets the requirements of 10 CFR 50.55a(a)(1) and 55a(h). It also meets GDC 1, 2, 4, 13, 20-24, and 29, and IEEE Std 603 for the design of safety-related reactor protection systems, engineered safety features systems, and other plant systems, and the guidelines of RG 1.152 and supporting industry standards for the design of digital systems.

On that basis, the staff concludes that, when properly installed and used, the Tricon PLC system is acceptable for safety-related use in nuclear power plants.

Principle Contributors: P. Loeser
D. Spaulding

Date: December 11, 2001